

Washer-Extractors

Cabinet Hardmount

Refer to Page 8 for Model Identification

Installation/Operation/Maintenance

Original Instructions

Keep These Instructions for Future Reference.

CAUTION: Read the instructions before using the machine.

(If this machine changes ownership, this manual must accompany machine.)



www.alliancelaundry.com

Part No. D1634ENR10
February 2019

Table of Contents

Safety Information.....	5
Explanation of Safety Messages.....	5
Important Safety Instructions.....	5
Safety Decals.....	7
Operator Safety.....	7
Introduction.....	8
Model Identification.....	8
Serial Plate Location.....	10
Manufacturing Date.....	10
Delivery Inspection.....	10
Replacement Parts	10
Customer Service.....	10
Specifications and Dimensions.....	11
General Specifications	11
Machine Dimensions.....	16
Mounting Bolt Hole Locations.....	19
Floor Mounting Layout	21
Installation.....	23
Pallet Removal.....	23
Machine Installation.....	24
Machine Foundation and Pad Installation.....	24
Machine Installation on Floor or Steel Base.....	26
Drain Connection.....	29
Drain Valve.....	30
Drain Pump, 7.5 kg / 20 lb. / 80 L Models outside of North America.....	33
Water Connection Requirements.....	34
Connecting Hoses.....	36
Water Reuse Connection (Optional).....	37
Reused Water Treatment.....	37
Water Reuse Tank Properties.....	37
Electrical Installation Requirements.....	38
Residual Current Device (RCD).....	39
Supply Protection Device.....	39
Supply Cable.....	40
Machine Protective Earth Connection and Equipotential Bonding.....	41
Input Power Conditioning.....	42
Input Voltage Requirements.....	42
Circuit Breakers and Quick Disconnects.....	42

© Copyright 2019, Alliance Laundry Systems LLC

All rights reserved. No part of the contents of this book may be reproduced or transmitted in any form or by any means without the expressed written consent of the publisher.

Connection Specifications.....	43
Single Phase Connection.....	43
Three Phase Connection.....	43
Phase Adder.....	44
Voltage Settings.....	44
Frequency Settings.....	44
Thermal Overload Protector.....	44
Electrical Specifications.....	45
Steam Requirements (Steam Heat Option Only).....	54
Steam Valve Installation.....	54
Supply Dispensing.....	55
Connection of External Liquid Supplies.....	55
Electrical Connection of External Liquid Soap Supply System.....	56
External Wait Control.....	57
Chemical Injection Supply System.....	57
Operation.....	58
Operating Instructions.....	58
Power Cut.....	59
Automatic Door-lock Unlocking Module (Optional).....	59
Maintenance.....	60
Maintenance.....	60
Daily.....	60
Beginning of Day.....	60
End of Day.....	60
Quarterly.....	61
Every 6 Months.....	61
Care of Stainless Steel.....	62
Disposal of Unit.....	63
Disconnecting the Machine.....	63
Disposal of Unit.....	63
China Restriction of hazardous substances (RoHS).....	64

Safety Information

Explanation of Safety Messages

Precautionary statements (“DANGER,” “WARNING,” and “CAUTION”), followed by specific instructions, are found in this manual and on machine decals. These precautions are intended for the personal safety of the operator, user, servicer, and those maintaining the machine.

	DANGER
Indicates an imminently hazardous situation that, if not avoided, will cause severe personal injury or death.	

	WARNING
Indicates a hazardous situation that, if not avoided, could cause severe personal injury or death.	

	CAUTION
Indicates a hazardous situation that, if not avoided, may cause minor or moderate personal injury or property damage.	

Additional precautionary statements (“IMPORTANT” and “NOTE”) are followed by specific instructions.

IMPORTANT: The word “IMPORTANT” is used to inform the reader of specific procedures where minor machine damage will occur if the procedure is not followed.

NOTE: The word “NOTE” is used to communicate installation, operation, maintenance or servicing information that is important but not hazard related.

Important Safety Instructions

	WARNING
To reduce the risk of fire, electric shock, serious injury or death to persons when using your washer, follow these basic precautions:	
W023	

- Read all instructions before using the washer.
- Install the washer according to the INSTALLATION instructions. Refer to the Earthing (grounding) instructions in the IN-

STALLATION manual for the proper earthing (grounding) of the washer. All connections for water, drain, electrical power and earthing (grounding) must comply with local codes and be made by licensed personnel when required. The machine has to be installed by qualified technicians.

- Do not install or store the washer where it will be exposed to water and/or weather.
- To prevent fire and explosion, keep the area around machine free from flammable and combustible products. Do not add the following substances or textiles containing traces of the following substances to the wash water: gasoline, kerosene, waxes, cooking oils, vegetable oils, machine oils, dry-cleaning solvents, flammable chemicals, thinners, or other flammable or explosive substances. These substances give off vapors that could ignite, explode or cause the fabric to catch fire by itself.
- Under certain conditions, hydrogen gas may be produced in a hot water system that has not been used for two weeks or more. HYDROGEN GAS IS EXPLOSIVE. If the hot water system has not been used for such a period, before using a washing machine or combination washer-dryer, turn on all hot water faucets and let the water flow from each for several minutes. This will release any accumulated hydrogen gas. The gas is flammable, do not smoke or use an open flame during this time.
- To reduce the risk of an electric shock or fire, DO NOT use an extension cord or an adapter to connect the washer to the electrical power source.
- Do not allow children to play on or in the washer. Close supervision of children is necessary when the washer is used near children. This appliance is not intended for use by young children or infirm persons without supervision. Young children should be supervised to ensure that they do not play with the appliance. This is a safety rule for all appliances.
- DO NOT reach and/or climb into the tub or onto the washer, ESPECIALLY if the wash drum is moving. This is an imminently hazardous situation that, if not avoided, will cause severe personal injury or death.
- Never operate the washer with any guards, panels and/or parts removed or broken. DO NOT bypass any safety devices or tamper with the controls.
- Use washer only for its intended purpose, washing textiles. Never wash machine parts or automotive parts in the machine. This could result in serious damage to the basket or tub.
- Use only low-sudsing, no-foaming types of commercial detergent. Be aware that hazardous chemicals may be present. Wear hand and eye protection when adding detergents and chemicals. Always read and follow manufacturer’s instructions on packages of laundry and cleaning aids. Heed all warnings or precautions. To reduce the risk of poisoning or

chemical burns, keep them out of the reach of children at all times [preferably in a locked cabinet].

- Do not use fabric softeners or products to eliminate static unless recommended by the manufacturer of the fabric softener or product.
- To avoid machine corrosion and component failure, do not use corrosive chemicals in the machine. Warranty claims related to damage caused by corrosive chemicals will be denied.
- Always follow the fabric care instructions supplied by the textile manufacturer.
- Loading door **MUST BE CLOSED** any time the washer is to fill, tumble or spin. **DO NOT** bypass the loading door switch by permitting the washer to operate with the loading door open. Do not attempt to open the door until the washer has drained and all moving parts have stopped.
- Be aware that hot water is used to flush the supply dispenser. Avoid opening the dispenser lid while the machine is running.
- Do not attach anything to the supply dispenser's nozzles, if applicable. The air gap must be maintained.
- Do not operate the machine without the water reuse plug or water reuse system in place, if applicable.
- Be sure water connections have a shut-off valve and that fill hose connections are tight. **CLOSE** the shut-off valves at the end of each wash day.
- Keep washer in good condition. Bumping or dropping the washer can damage safety features. If this occurs, have washer checked by a qualified service person.
- **DANGER:** Before inspecting or servicing machine, power supply must be turned **OFF**. The servicer needs to wait for at least 10 minutes after turning the power **OFF** and needs to check for residual voltage with a voltage meter. The inverter remains charged with high voltage for some time after powering **OFF**. This is an imminently hazardous situation that, if not avoided, will cause severe personal injury or death. Before starting inspection of the inverter, check for residual voltage across main circuit terminals + and -. This voltage must be below 30 VDC before the servicer can access the inverter for inspection.
- Do not repair or replace any part of the washer, or attempt any servicing unless specifically recommended in the user-maintenance instructions or in published user-repair instructions that the user understands and has the skills to carry out. **ALWAYS** disconnect the washer from electrical, power and water supplies before attempting any service.
- Disconnect the power by turning off the circuit breaker or by unplugging the machine. Replace worn power cords.
- Before the washer is removed from service or discarded, remove the door to the washing compartment.
- Failure to install, maintain, and/or operate this washer according to the manufacturer's instructions may result in conditions which can produce bodily injury and/or property damage.

NOTE: The WARNING and IMPORTANT SAFETY INSTRUCTIONS appearing in this manual are not meant to cover all possible conditions and situations that may occur. Observe and be aware of other labels and precautions that are located on the machine. They are intended to provide instruction for safe use of the machine. Common sense, caution and care must be exercised when installing, maintaining, or operating the washer.

Always contact your dealer, distributor, service agent or the manufacturer on any problems or conditions you do not understand.

NOTE: For European Union member states only: Electrical safety of the washers described in this manual is in compliance with the requirements of the European standard EN60204-1.

	DANGER
<p>Electrical shock hazard will result in death or serious injury. Disconnect electric power and wait ten (10) minutes before servicing.</p>	
W911	

	WARNING
<p>Machine installations must comply with minimum specifications and requirements stated in the applicable Installation Manual, any applicable municipal building codes, water supply requirements, electrical wiring regulations and any other relevant statutory regulations. Due to varied requirements and applicable local codes, this machine must be installed, adjusted, and serviced by qualified maintenance personnel familiar with applicable local codes and the construction and operation of this type of machinery. They must also be familiar with the potential hazards involved. Failure to observe this warning may result in personal injury, property damage, and/or equipment damage, and will void the warranty.</p>	
W820	

	WARNING
<p>Dangerous voltages are present inside the machine. Only qualified personnel should attempt adjustments and troubleshooting. Disconnect power from the machine before removing any cover and guards, and before attempting any service procedures.</p>	
W736	

IMPORTANT: Ensure that the machine is installed on a level floor of sufficient strength. Ensure that the recommended clearances for inspection and maintenance are provided. Never allow the inspection and maintenance space to be blocked.

	WARNING
<p>Never touch internal or external steam pipes, connections, or components. These surfaces can be extremely hot and will cause severe burns. The steam must be turned off and the pipe, connections, and components allowed to cool before the pipe can be touched.</p>	
SW014	

	WARNING
<p>Install the machine on a level floor of sufficient strength. Failure to do so may result in conditions which can produce serious injury, death and/or property damage.</p>	
W703	

	WARNING
<p>Never interfere with the setting of the door handle. Never try to modify the setting or repair the handle! Any interference with its setting may lead to serious risk for the operator! A damaged or incorrectly functioning door handle must always be immediately replaced with a new original part.</p>	
C014	

NOTE: All appliances are produced according the EMC-directive (Electro-Magnetic-Compatibility). They can be used in restricted surroundings only (comply minimally with class A requirements). For safety reasons there must be kept the necessary precaution distances with sensitive electrical or electronic device(s). These machines are not intended for domestic use by private consumers in the home environment.

Safety Decals

Safety decals appear at crucial locations on the machine. Failure to maintain legible safety decals could result in injury to the operator or service technician.

Use manufacturer-authorized spare parts to avoid safety hazards.

Operator Safety

	WARNING
<p>NEVER insert hands or objects into basket until it has completely stopped. Doing so could result in serious injury.</p>	
SW012	

Machines referred to by model in this manual are intended to be used by the general public in applications such as:

- staff areas in shops, offices, kitchens and other working environments
- by clients in hotels, motels and other residential type environments
- areas for communal use in blocks of flats or in launderettes
- any other similar applications

Installation of these machines must fully conform to the instructions contained in this manual.

The following maintenance checks must be performed daily:

1. Verify that all warning labels are present and legible, replace as necessary.
2. Check door interlock before starting operation of the machine:
 - a. Attempt to start the machine with the door open. The machine should not start.
 - b. Close the door without locking it and start the machine. The machine should not start.
 - c. Attempt to open the door while a cycle is in progress. The door should not open.

If the door lock and interlock are not functioning properly, disconnect power and call a service technician.

3. Do not attempt to operate the machine if any of the following conditions are present:
 - a. The door does not remain securely locked during the entire cycle.
 - b. Excessively high water level is evident.
 - c. Machine is not connected to a properly grounded circuit.

Do not bypass any safety devices in the machine.

	WARNING
<p>Operating the machine with severe out-of-balance loads could result in personal injury and serious equipment damage.</p>	
W728	

Introduction

Model Identification

Information in this manual is applicable to these models:

A105_ARIES	IAC520J	IAH180J	IAW240R
A135_ARIES	IAC520R	IAH180R	IAX080J
A180_ARIES	IAE080J	IAH240J	IAX080R
A240_ARIES	IAE080R	IAH240R	IAX105J
A280_ARIES	IAE105J	IAH280J	IAX105R
A80_ARIES	IAE105R	IAH280R	IAX135J
IA105_ARIES	IAE135J	IAH332J	IAX135R
IA105_ARIES-ELITE	IAE135R	IAH332R	IAX180J
IA135_ARIES	IAE180J	IAH520J	IAX180R
IA135_ARIES-ELITE	IAE180R	IAH520R	IAX240J
IA180_ARIES	IAE240J	IAU080J	IAX240R
IA180_ARIES-ELITE	IAE240R	IAU080R	IAX280J
IA240_ARIES	IAE280J	IAU105J	IAX280R
IA240_ARIES-ELITE	IAE280R	IAU105R	IAX332J
IA280_ARIES	IAG080J	IAU135J	IAX332R
IA280_ARIES-ELITE	IAG080R	IAU135R	IAX520J
IA332_ARIES	IAG105J	IAU180J	IAX520R
IA332_ARIES-ELITE	IAG105R	IAU180R	WMA103E
IA520_ARIES	IAG135J	IAU240J	WMA103E_ARIES
IA520_ARIES-ELITE	IAG135R	IAU240R	WMA123E_ARIES
IA80_ARIES	IAG180J	IAU280R	WMA153E
IA80_ARIES-ELITE	IAG180R	IAU332J	WMA153E_ARIES
IAB180J	IAG240J	IAU332R	WMA203E
IAB180R	IAG240R	IAU520J	WMA203E_ARIES
IAC080J	IAG280J	IAU520R	WMA253E
IAC080R	IAG280R	IAW080J	WMA253E_ARIES
IAC105J	IAG332J	IAW080R	WMA303E
IAC105R	IAG332R	IAW105J	WMA303E_ARIES
IAC135J	IAG520J	IAW105R	WMA403E
IAC135R	IAG520R	IAW135J	WMA403E_ARIES

Table continues...

IAC180J	IAH080J	IAW135R	WMA73E
IAC180R	IAH080R	IAW180J	WMA73E_ARIES
IAC240J	IAH105J	IAW180R	WMA83E
IAC240R	IAH105R	IAW240J	WMA83E_ARIES
IAC280J	IAH135J	IAY105R	IAY080J
IAC280R	IAH135R	IAY180R	IAY135J
IAC332J	IAY105J	IAY280R	IAY240J
IAC332R	IAY180J	IAY520R	IAY332J
IAY080R	IAY280J	IA105_JLA_ARIES-ELITE	IA180_JLA
IAY135R	IAY520J	IA135_JLA	IA240_JLA
IAY240R	IA105_JLA	IA135_JLA_ARIES	IA280_JLA
IAY332R	IA105_JLA_ARIES	IA135_JLA_ARIES-ELITE	IA332_JLA
IA520_JLA		IA80_JLA	

Serial Plate Location

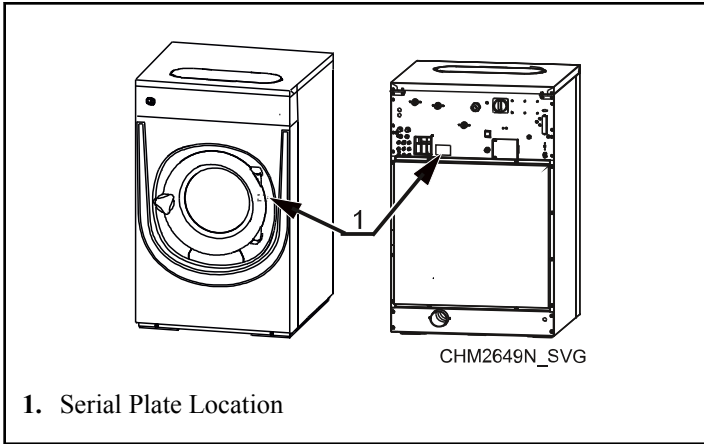

Figure 1

The serial plate is located on the rear panel of the machine and on the frame inside the machine.

Always provide the machine serial number when ordering parts or when seeking technical assistance.

Manufacturing Date

The manufacturing date for your unit can be found on the serial number. The last two characters indicate first the year and then the month. Refer to *Table 1* and *Table 2*. For example, a unit with serial number 520I000001DK was manufactured in May 2015.

Manufacturing Date - Year	
Year	Serial Number Character
2009	P
2010	R
2011	T
2012	V
2013	X
2014	B
2015	D
2016	F
2017	H
2018	K
2019	M
2020	Q

Table 1

Manufacturing Date - Month	
Month	Serial Number Character
January	A or B
February	C or D
March	E or F
April	G or H
May	J or K
June	L or M
July	N or Q
August	P or S
September	R or U
October	T or W
November	V or Y
December	X or Z

Table 2

Delivery Inspection

Upon delivery, visually inspect crate, protective cover, and unit for any visible shipping damage. If signs of possible damage are evident, have the carrier note the condition on the shipping papers before the shipping receipt is signed, or advise the carrier of the condition as soon as it is discovered.

Replacement Parts

If literature or replacement parts are required, contact the source from which the machine was purchased or contact Alliance Laundry Systems at +1 (920) 748-3950 for the name and address of the nearest authorized parts distributor.

Customer Service

For technical assistance, contact your local distributor or contact:

Alliance Laundry Systems
 Shepard Street
 P.O. Box 990
 Ripon, WI 54971-0990
 U.S.A.
www.alliancelaundry.com
 Phone: +1 (920) 748-3121 Ripon, Wisconsin

Specifications and Dimensions

General Specifications

Specifications	7.5 kg/ 20 lb./ 80 L Models	10.5 kg/ 25 lb./ 105 L Models	13.5 kg/ 30 lb./ 135 L Models	18 kg/ 40 lb./ 180 L Models	24 kg/ 55 lb./ 240 L Models	28 kg/ 70 lb./ 280 L Models	35 kg/ 80 lb./ 332 L Models	52 kg/ 120 lb./ 520 L Models
Overall Dimensions								
Overall width, in. [mm]	25.98 [660]	29.53 [750]	29.53 [750]	35.03 [890]	35.03 [890]	35.03 [890]	41.73 [1060]	41.73 [1060]
Overall height, in. [mm]	43.89 [1115]	48.22 [1225]	48.22 [1225]	55.51 [1410]	55.51 [1410]	55.51 [1410]	59.05 [1500]	59.05 [1500]
Overall depth, in. [mm]	30.91 [785]	30.91 [785]	35.43 [900]	36.02 [915]	41.73 [1060]	44.68 [1135]	40.55 [1030]	51.77 [1315]
Weight and Shipping Information								
Net weight, lbs. [kg] (100G)	298 [135]	375 [170]	419 [190]	563 [255]	606 [275]	639 [290]	904 [410]	1146 [520]
Net weight, lbs. [kg] (150G)	N/A	N/A	N/A	N/A	N/A	N/A	904 [410]	N/A
Net weight, lbs. [kg] (175G)	298 [135]	375 [170]	419 [190]	695 [315]	728 [330]	783 [355]	N/A	N/A
Shipping weight, lbs. [kg](100G)	320 [145]	408 [185]	441 [200]	595 [270]	639 [290]	672 [305]	992 [450]	1257 [570]
Shipping weight, lbs. [kg](150G)	N/A	N/A	N/A	N/A	N/A	N/A	1147 [520]	N/A
Shipping weight, lbs. [kg](175G)	320 [145]	408 [185]	441 [200]	739 [335]	783 [355]	849 [385]	N/A	N/A

Table continues...

Specifications and Dimensions

Specifi- cations	7.5 kg/ 20 lb./ 80 L Models	10.5 kg/ 25 lb./ 105 L Models	13.5 kg/ 30 lb./ 135 L Models	18 kg/ 40 lb./ 180 L Models	24 kg/ 55 lb./ 240 L Models	28 kg/ 70 lb./ 280 L Models	35 kg/ 80 lb./ 332 L Models	52 kg/ 120 lb./ 520 L Models
Shipping dimensions (WxDxH), in. [mm]	27.95 x 32.87 x 49.02 [710 x 835 x 1245]	31.50 x 32.87 x 53.35 [800 x 835 x 1355]	31.50 x 37.40 x 53.35 [800 x 950 x 1355]	36.42 x 38.19 x 61.02 [925 x 970 x 1550]	36.42 x 44.49 x 61.02 [925 x 1130 x 1550]	36.42 x 46.85 x 61.02 [925 x 1190 x 1550]	43.31 x 43.31 x 66.93 [1100 x 1100 x 1700]	43.31 x 54.53 x 66.93 [1100 x 1385 x 1700]
Wash Cylinder Information								
Cylinder diameter in. [mm]	20.87 [530]	24.40 [620]	24.40 [620]	29.53 [750]	29.53 [750]	29.53 [750]	35.98 [914]	35.98 [914]
Cylinder depth in. [mm]	13.78 [350]	13.78 [350]	17.72 [450]	16.14 [410]	21.46 [545]	24.41 [620]	19.88 [505]	31.10 [790]
Cylinder volume ft ³ [l]	2.6 [75]	3.7 [105]	4.8 [135]	6.4 [180]	8.5 [240]	9.9 [280]	11.7 [332]	18.36 [520]
Door Opening Information								
Door opening size, in. [mm]	13 [330]	16.14 [410]	16.14 [410]	18.11 [460]	18.11 [460]	18.11 [460]	19.84 [504]	19.84 [504]
Height of door bottom above floor, in. [mm]	13.74 [349]	13.46 [342]	13.46 [342]	18.31 [465]	18.31 [465]	18.31 [465]	18.31 [465]	18.31 [465]
Drive Train Information								
Number of motors in drive train	1	1	1	1	1	1	1	1
Motor Size, hp [kW] (100G)	0.74 [0.55]	0.67 [0.5]	1 [0.75]	1 [0.75]	1.48 [1.1]	1.5 [2.01]	2.95 [2.2]	5.36 [4]
Motor Size, hp [kW] (150G)	N/A	N/A	N/A	N/A	N/A	N/A	2.95 [2.2]	N/A

Table continues...

Specifi- cations	7.5 kg/ 20 lb./ 80 L Models	10.5 kg/ 25 lb./ 105 L Models	13.5 kg/ 30 lb./ 135 L Models	18 kg/ 40 lb./ 180 L Models	24 kg/ 55 lb./ 240 L Models	28 kg/ 70 lb./ 280 L Models	35 kg/ 80 lb./ 332 L Models	52 kg/ 120 lb./ 520 L Models
Motor Size, hp [kW] (175G)	0.74 [0.55]	0.67 [0.5]	1 [0.75]	1.48 [1.1]	2.01 [1.5]	2.01 [1.5]	N/A	N/A
Cylinder Speeds								
Wash, RPM	50	46	46	42	42	42	38	38
Extraction, RPM (100G)	580	540	540	490	490	490	N/A	440
Extraction, RPM (150G)	N/A	N/A	N/A	N/A	N/A	N/A	540	N/A
Extraction, RPM (175G)	770	710	710	645	645	645	N/A	N/A
Heating								
Electric, kW	6 / 9 (4.6)	6 / 9 / 12	9 / 12	12 / 18	18	21.9	27	40.6
Steam, psi [bar]	15-116 [1-8]	15-116 [1-8]	15-116 [1-8]	15-116 [1-8]	15-116 [1-8]	15-116 [1-8]	15-116 [1-8]	15-116 [1-8]
Hot water, °F [°C]	194 [90]	194 [90]	194 [90]	194 [90]	194 [90]	194 [90]	194 [90]	194 [90]
Noise Emissions								
Wash se- quence, dB (100 G)	49	49	50	48	50	50	50	50
Wash se- quence, dB (150 G)	N/A	N/A	N/A	N/A	N/A	N/A	50	N/A
Wash se- quence, dB (175 G)	49	49	50	50	50	50	N/A	N/A
Extract se- quence, dB (100G)	53	53	65	55	65	65	65	65

Table continues...

Specifications and Dimensions

Specifi- cations	7.5 kg/ 20 lb./ 80 L Models	10.5 kg/ 25 lb./ 105 L Models	13.5 kg/ 30 lb./ 135 L Models	18 kg/ 40 lb./ 180 L Models	24 kg/ 55 lb./ 240 L Models	28 kg/ 70 lb./ 280 L Models	35 kg/ 80 lb./ 332 L Models	52 kg/ 120 lb./ 520 L Models
Extract se- quence, dB (150G)	N/A	N/A	N/A	N/A	N/A	N/A	65	N/A
Extract se- quence, dB (175 G)	53	53	65	65	65	65	N/A	N/A
Floor Load Data								
Maximum static load on floor, lbs. [kN] (100G)	427 [1.9]	495 [2.2]	607 [2.7]	764 [3.4]	877 [3.9]	944 [4.2]	1461 [6.5]	1888 [8.4]
Maximum static load on floor, lbs. [kN] (150G)	N/A	N/A	N/A	N/A	N/A	N/A	1461 [6.5]	N/A
Maximum static load on floor, lbs. [kN] (175G)	427 [1.9]	495 [2.2]	607 [2.7]	899 [4.0]	1012 [4.5]	1101 [4.9]	N/A	N/A
Static floor pressure lbs./ft ² [kN/m ²] (100G)	90 [4.29]	91 [4.37]	96 [4.58]	96 [4.56]	93 [4.45]	93 [4.45]	133 [6.38]	133 [6.36]
Static floor pressure lbs./ft ² [kN/m ²] (150G)	N/A	N/A	N/A	N/A	N/A	N/A	133 [6.38]	N/A
Maximum dynamic load on floor, lbs. [kN] (100G)	360 ± 337 [1.6 ± 1.5]	427 ± 450 [1.9 ± 2.0]	495 ± 562 [2.2 ± 2.5]	607 ± 719 [2.7 ± 3.2]	674 ± 967 [3.0 ± 4.3]	719 ± 1124 [3.2 ± 5.0]	1191 ± 1866 [5.3 ± 5.5]	1506 ± 1843 [6.7 ± 8.2]

Table continues...

Specifi- cations	7.5 kg/ 20 lb./ 80 L Models	10.5 kg/ 25 lb./ 105 L Models	13.5 kg/ 30 lb./ 135 L Models	18 kg/ 40 lb./ 180 L Models	24 kg/ 55 lb./ 240 L Models	28 kg/ 70 lb./ 280 L Models	35 kg/ 80 lb./ 332 L Models	52 kg/ 120 lb./ 520 L Models
Maximum dynamic load on floor, lbs. [kN] (150G)	N/A	N/A	N/A	N/A	N/A	N/A	1191 ± 1866 [5.3 ± 8.3]	N/A
Maximum dynamic load on floor, lbs. [kN] (175G)	360 ± 562 [1.6 ± 2.5]	427 ± 764 [1.9 ± 3.4]	495 ± 989 [2.2 ± 4.4]	764 ± 1259 [3.4 ± 5.6]	832 ± 1664 [3.7 ± 7.4]	877 ± 1956 [3.9 ± 8.7]	N/A	N/A
Dynamic floor pres- sure lbs./ft ² [kN/m ²] (100G)	75 ± 71 [3.62 ± 3.39]	79 ± 83 [3.78 ± 3.98]	78 ± 89 [3.73 ± 4.24]	76 ± 90 [3.62 ± 4.29]	71 ± 102 [3.42 ± 4.91]	71 ± 111 [3.41 ± 5.30]	N/A	106 ± 130 [5.07 ± 6.21]
Dynamic floor pres- sure lbs./ft ² [kN/m ²] (150G)	N/A	N/A	N/A	N/A	N/A	N/A	109 ± 170 [5.21 ± 8.15]	N/A
Frequency of dynamic load, Hz (100G)	9.7	8.9	8.9	8.2	8.2	8.2	9	7.4
Frequency of dynamic load, Hz (150G)	N/A	N/A	N/A	N/A	N/A	N/A	9	N/A
Frequency of dynamic load, Hz (175G)	12.8	11.8	11.8	10.8	10.8	10.8	N/A	N/A
General Data								
Ambient Tempera- ture, °F [°C]	41-95 [5-35]							

Table continues...

Specifications and Dimensions

Specifi- cations	7.5 kg/ 20 lb./ 80 L Models	10.5 kg/ 25 lb./ 105 L Models	13.5 kg/ 30 lb./ 135 L Models	18 kg/ 40 lb./ 180 L Models	24 kg/ 55 lb./ 240 L Models	28 kg/ 70 lb./ 280 L Models	35 kg/ 80 lb./ 332 L Models	52 kg/ 120 lb./ 520 L Models
Relative Humidity	30%-90% without condensation							
Height above sea level ft. [m]	up to 3280 [up to 1000]							
Storage Temperature, °F [°C]	34-131 [1-55]							

Machine Dimensions

NOTE: Beginning January, 2018: 80 L (20 lb.) and 105 L (25 lb.) models have embossed side panels.

NOTE: Beginning February, 2018: 135 L (30 lb.) models have embossed side panels.

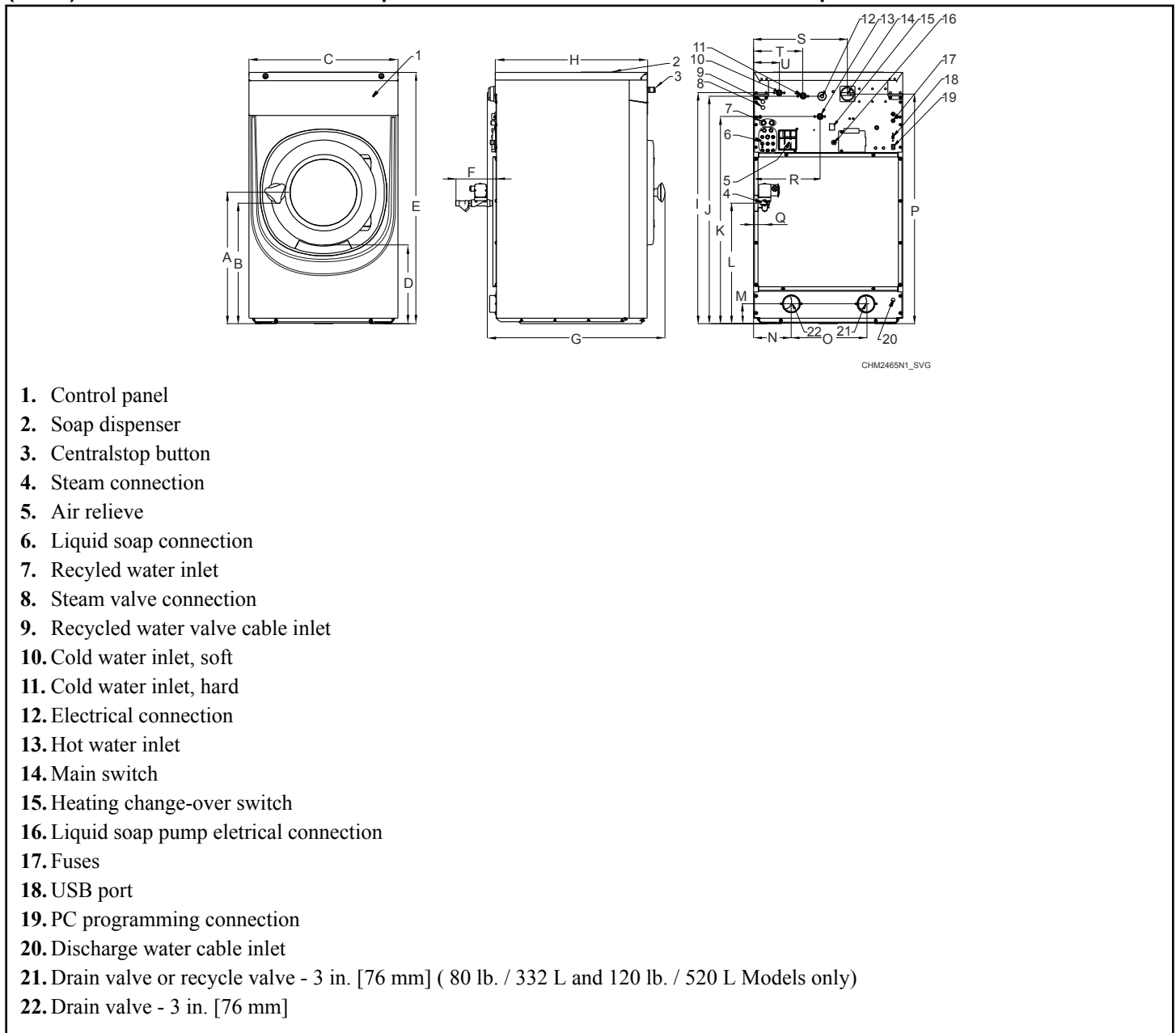

Figure 2

Specifications and Dimensions

Specifi- cation	7.5 kg/ 20 lb./ 80 L Models, in. [mm]	10.5 kg/ 25 lb./ 105 L Models, in. [mm]	13.5 kg/ 30 lb./ 135 L Models, in. [mm]	18 kg/ 40 lb./ 180 L Models, in. [mm]	24 kg/ 55 lb./ 240 L Models, in. [mm]	28 kg/ 70 lb./ 280 L Models, in. [mm]	35 kg/ 80 lb./ 332 L Models, in. [mm]	52 kg/ 120 lb./ 520 L Models, in. [mm]
A	23.14 [588]	24.60 [625]	24.60 [625]	30.31 [770]	30.31 [770]	30.31 [770]	31.41 [798]	31.41 [798]
B	21.25 [540]	22.71 [577]	22.71 [577]	28.42 [722]	28.42 [722]	28.42 [722]	29.52 [750]	29.52 [750]
C	25.98 [660]	29.53 [750]	29.53 [750]	35.03 [890]	35.03 [890]	35.03 [890]	41.73 [1060]	41.73 [1060]
D	13.74 [349]	13.46 [342]	13.46 [342]	18.31 [465]	18.31 [465]	18.31 [465]	18.31 [465]	18.31 [465]
E	43.89 [1115]	48.22 [1225]	48.22 [1225]	55.51 [1410]	55.51 [1410]	55.51 [1410]	59.05 [1500]	59.05 [1500]
F	7.08 [180]	7.56 [192]	7.56 [192]	4.72 [120]	4.72 [120]	4.72 [120]	5.71 [145]	5.71 [145]
G	30.91 [785]	30.91 [785]	35.43 [900]	36.02 [915]	41.73 [1060]	44.68 [1135]	40.55 [1030]	51.77 [1315]
H	26.61 [676]	26.61 [676]	31.14 [791]	32.13 [816]	37.83 [961]	40.79 [1036]	36.89 [937]	48.11 [1222]
I	40.35 [1025]	44.68 [1135]	44.68 [1135]	51.85 [1317]	51.85 [1317]	51.85 [1317]	55.63 [1413]	52.44 [1332]
J	39.76 [1010]	44.09 [1120]	44.09 [1120]	51.06 [1297]	51.06 [1297]	51.06 [1297]	53.78 [1366]	54.09 [1374]
K	36.22 [920]	40.55 [1030]	40.55 [1030]	47.72 [1212]	47.72 [1212]	47.72 [1212]	52.21 [1326]	55.67 [1414]
L	21.06 [535]	18.89 [480]	18.89 [480]	20.79 [528]	20.79 [528]	20.79 [528]	20.79 [528]	20.79 [528]
M	3.46 [88]	3.85 [98]	3.95 [98]	5.12 [130]	5.12 [130]	5.12 [130]	4.72 [120]	4.72 [120]
N	6.53 [166]	8.85 [225]	8.85 [225]	11.02 [280]	11.02 [280]	11.02 [280]	12.52 [318]	12.52 [318]
O	N/A	N/A	N/A	N/A	N/A	N/A	18.98 [482]	18.98 [482]
P	40.15 [1020]	44.48 [1130]	44.48 [1130]	50 [1270]	50 [1270]	50 [1270]	53.11 [1349]	53.11 [1349]
Q	1.89 [48]	1.65 [42]	1.65 [42]	2.13 [54]	2.13 [54]	2.13 [54]	2.60 [66]	2.60 [66]
R	11.53 [293]	13.31 [338]	13.31 [338]	11.93 [303]	11.93 [303]	11.93 [303]	15.08 [383]	14.29 [363]
S	16.34 [415]	19.88 [505]	19.88 [505]	24.61 [625]	24.61 [625]	24.61 [625]	26.42 [671]	26.41 [671]
T	8.58 [218]	8.58 [218]	8.58 [218]	8.58 [218]	8.58 [218]	8.58 [218]	9.76 [248]	8.78 [223]

Table 3 continues...

	7.5 kg/ 20 lb./ 80 L Models,	10.5 kg/ 25 lb./ 105 L Models,	13.5 kg/ 30 lb./ 135 L Models,	18 kg/ 40 lb./ 180 L Models,	24 kg/ 55 lb./ 240 L Models,	28 kg/ 70 lb./ 280 L Models,	35 kg/ 80 lb./ 332 L Models,	52 kg/ 120 lb./ 520 L Models,
Specifi- cation	in. [mm]	in. [mm]	in. [mm]	in. [mm]	in. [mm]	in. [mm]	in. [mm]	in. [mm]
U	4.44 [113]	4.44 [113]	4.44 [113]	4.44 [113]	4.44 [113]	4.44 [113]	4.45 [113]	3.46 [88]

Table 3

Mounting Bolt Hole Locations

7.5 kg / 20 lb. / 80 L, 10.5 kg/ 25 lb. / 105 L and 13.5 kg / 30 lb. / 135 L with 100 G or 175 G Extraction; 18 kg/ 40 lb. / 180 L, 24 kg / 55 lb. / 240 L and 28 kg / 70 lb. / 280 L with 100 G Extraction

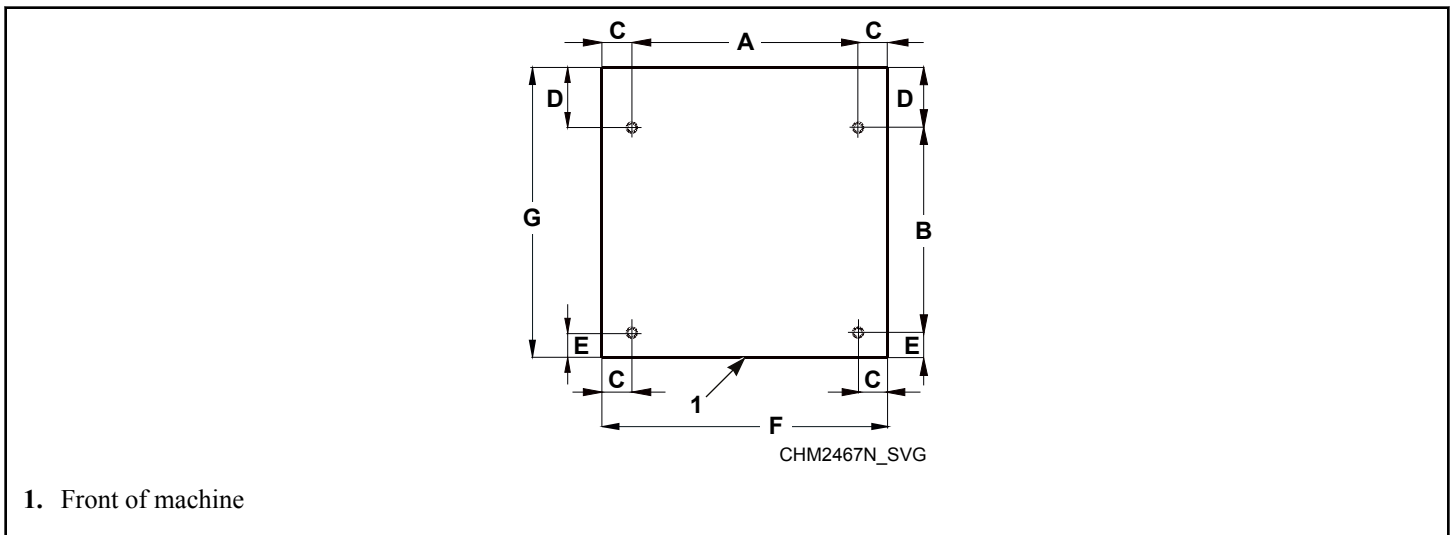

Figure 3

Mounting Bolt Hole Locations, in. [mm]						
Spec ifica- tion	7.5 kg / 20 lb. / 80 L (100G or 175G)	10.5 kg/ 25 lb. / 105 L (100G or 175G)	13.5 kg / 30 lb. / 135 L (100G or 175G)	18 kg/ 40 lb. / 180 L (100G)	24 kg / 55 lb. / 240 L (100G)	28 kg / 70 lb. / 280 L (100G)
A	20.55 [522]	24.21 [615]	24.21 [615]	29.57 [751]	29.57 [751]	29.57 [751]
B	18.66 [474]	18.66 [474]	22.59 [574]	22.40 [569]	28.11 [714]	31.06 [789]
C	2.71 [69]	2.85 [67.5]	2.65 [67.5]	2.74 [69.5]	2.74 [69.5]	2.74 [69.5]
D	5.47 [139]	5.47 [139]	6.06 [154]	8.68 [220.5]	8.68 [220.5]	8.68 [220.5]
E	2.26 [57.5]	2.26 [57.5]	2.26 [57.5]	1.97 [50]	1.97 [50]	1.97 [50]

Table 4 continues...

Mounting Bolt Hole Locations, in. [mm]						
Spec ifica- tion	7.5 kg / 20 lb. / 80 L (100G or 175G)	10.5 kg/ 25 lb. / 105 L (100G or 175G)	13.5 kg / 30 lb. / 135 L (100G or 175G)	18 kg/ 40 lb. / 180 L (100G)	24 kg / 55 lb. / 240 L (100G)	28 kg / 70 lb. / 280 L (100G)
F	25.98 [660]	29.52 [750]	29.52 [750]	35.04 [890]	35.04 [890]	35.04 [890]
G	26.39 [670.5]	26.39 [670.5]	30.92 [785.5]	33.01 [838.5]	38.76 [984.5]	41.71 [1059.5]

Table 4

18 kg / 40 lb. / 180 L, 24 kg / 55 lb. / 240 L and 28 kg / 70 lb. / 280 L with 175 G Extraction; 35 kg / 80 lb. / 332 L with 100 G or 150 G Extraction and 52 kg / 120 lb. / 520 L

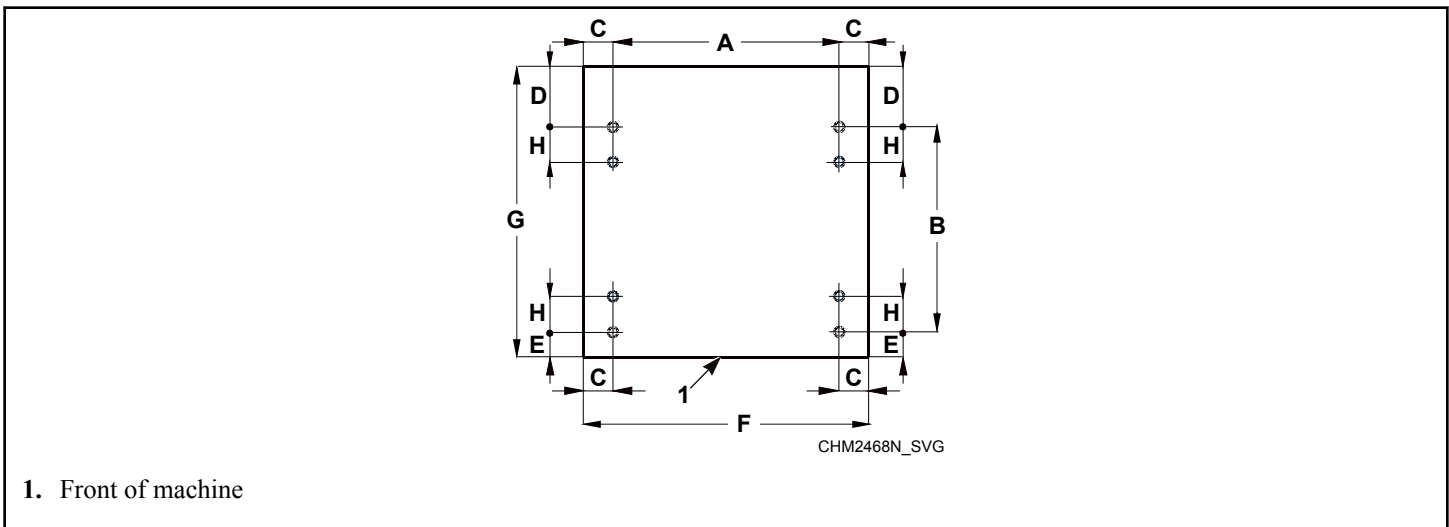

Figure 4

Mounting Bolt Hole Locations, in. [mm]					
Speci- fica- tion	18 kg / 40 lb. / 180 L (175G)	24 kg / 55 lb. / 240 L (175G)	28 kg / 70 lb. / 280 L (175G)	35 kg / 80 lb. / 332 L (100G or 150G)	52 kg / 120 lb. / 520 L
A	29.57 [751]	29.57 [751]	29.57 [751]	36.22 [920]	36.22 [920]
B	22.40 [569]	28.11 [714]	31.06 [789]	25.16 [639]	36.38 [924]
C	2.74 [69.5]	2.74 [69.5]	2.74 [69.5]	2.76 [70]	2.76 [70]
D	8.68 [220.5]	8.68 [220.5]	8.68 [220.5]	10.69 [271.5]	10.69 [271.5]
E	1.97 [50]	1.97 [50]	1.97 [50]	1.97 [50]	1.97 [50]
F	35.04 [890]	35.04 [890]	35.04 [890]	41.73 [1060]	41.73 [1060]

Table 5 continues...

Mounting Bolt Hole Locations, in. [mm]					
Speci- fica- tion	18 kg/ 40 lb. / 180 L (175G)	24 kg / 55 lb. / 240 L (175G)	28 kg / 70 lb. / 280 L (175G)	35 kg / 80 lb. / 332 L (100G or 150G)	52 kg / 120 lb. / 520 L
G	33.01 [838.5]	38.76 [984.5]	41.71 [1059.5]	37.82 [960.5]	49.04 [1245.5]
H	3.23 [82]	3.23 [82]	3.23 [82]	3.23 [82]	3.23 [82]

Table 5

Floor Mounting Layout

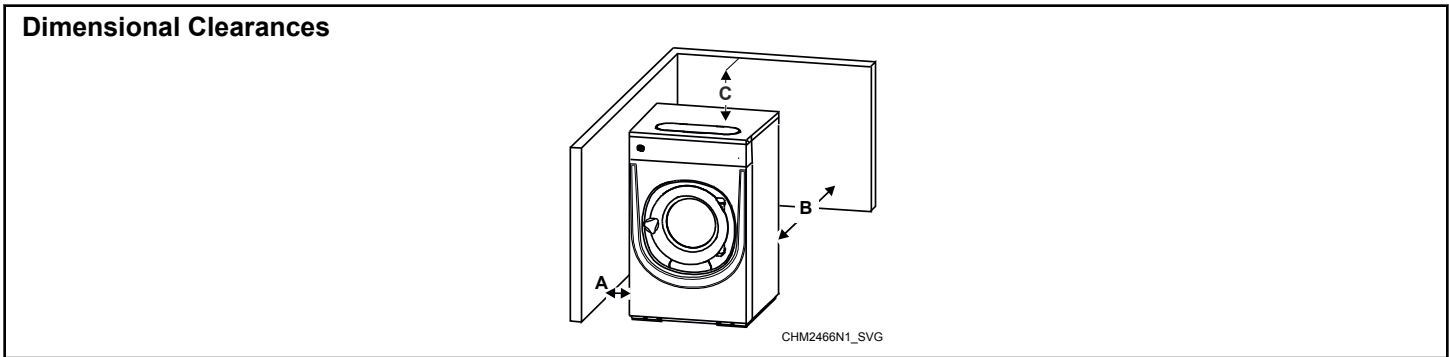

Figure 5

Dimensional Clearances, in. [mm]									
Models		7.5 kg/ 20 lb./ 80 L	10.5 kg/ 25 lb./ 105 L	13.5 kg/ 30 lb./ 135 L	18 kg/ 40 lb./ 180 L	24 kg/ 55 lb./ 240 L	28 kg/ 70 lb./ 280 L	35 kg/ 80 lb./ 332 L	52 kg/ 120 lb./ 520 L
A	Distance of machine to side wall or other machine (minimum)	0.79 [20]	0.79 [20]	0.79 [20]	0.79 [20]	0.79 [20]	0.79 [20]	0.79 [20]	0.79 [20]
B	Distance to wall (minimum)	20 [500]	20 [500]	20 [500]	20 [500]	20 [500]	20 [500]	20 [500]	20 [500]
C	Distance above machine (minimum)	31.49 [800]	31.49 [800]	31.49 [800]	45.27 [1150]	45.27 [1150]	45.27 [1150]	41.33 [1050]	52.36 [1330]

Table 6

Installation

Pallet Removal

The machine is delivered bolted onto the transport pallet and packed in shrink-wrap foil or box.

1. Remove packing from machine.
2. Remove front and rear panel.
3. Remove bolts between machine and pallet.
4. When machine is lifted off pallet, make sure the machine does not come down on the floor with either of the rear corners first. The machine's side panel can be damaged.

NOTE: Two self-adhesive rubber stop-blocks are supplied with the machine. They may be applied as paint protection when opening the door.

Machine Installation

Install the machine close to a floor drain or open drain.

Machine Foundation and Pad Installation

A concrete pad may be constructed to elevate a machine. Care must be exercised in the design of the pad due to the force exer-

ted by the machine during extract. This concrete pad, recommended not to exceed 7.87 inches [200 mm] above existing floor, must be placed, reinforced with rebar and tied to the existing floor.

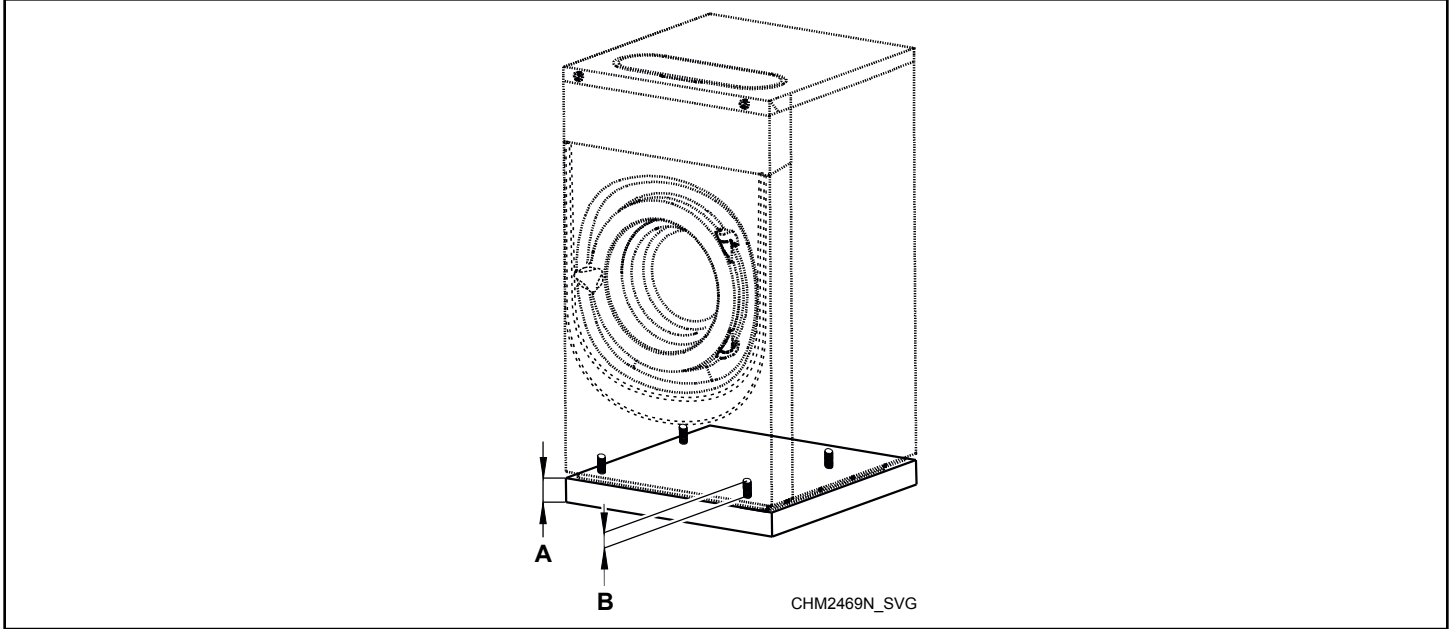

Figure 6

Specification	in. [mm]
A	5.9 - 7.87 [150 - 200]
B	1.58 [40]

Table 7

IMPORTANT: Do NOT install a pad on top of the existing floor. The foundation and pad must be constructed and tied together as one piece.

If the existing floor is not reinforced concrete at least of minimum thickness 4.72 in [120 mm] or an elevated pad is desired, the following steps must be performed:

1. Cut a hole larger than the machine base through the existing floor, refer to *Figure 7*.
2. Excavate to a depth as indicated in *Table 8* from the top of the existing floor.
3. Wet the excavated area and spread over with cement.
4. Drill holes [refer to manufacturer's requirements for drill hole size] for the perimeter reinforcing bar into the existing floor.
5. Clean out debris from each reinforcing bar hole.
6. Fill half the hole depth with acrylic adhesive.
7. Using #4 (60 ksi) reinforcing bar, tie new pad to existing floor making sure to tie reinforcing bars at the intersections and using proper reinforcing bar supports to hold bars at the proper depth in the pad.

NOTE: When inserting the reinforcing bar, note the locations (and space requirements) for drilling holes for chemical anchor bolts.

8. Allow adhesive around reinforcing bar to cure properly, refer to adhesive manufacturer for recommended cure times.
9. Pour concrete into the prepared base.
10. Level the surface carefully into a horizontal plane.
11. Allow concrete to cure for at least one week before installation of the machine.

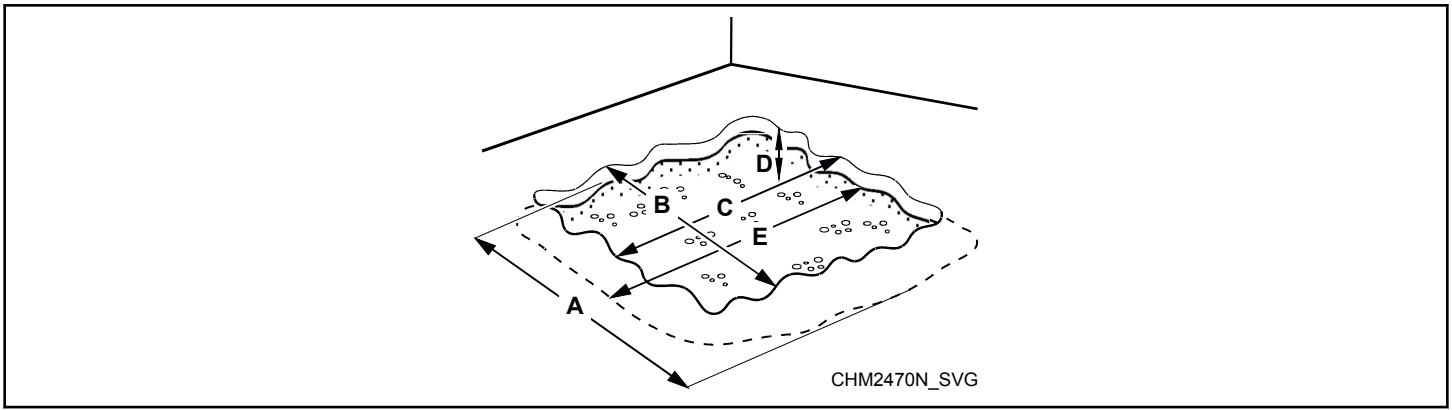

Figure 7

Specification, in. [mm]	7.5 kg / 20 lb. / 80 L	10.5 kg/ 25 lb. / 105 L	13.5 kg / 30 lb. / 135 L	18 kg/ 40 lb. / 180 L	24 kg / 55 lb. / 240 L	28 kg / 70 lb. / 280 L	35 kg / 80 lb. / 332 L	52 kg / 120 lb. / 520 L
A	30.71 [780]	34.25 [870]	34.25 [870]	39.76 [1010]	39.76 [1010]	39.76 [1010]	46.46 [1180]	46.46 [1180]
B	Refer to <i>Table 4</i> or <i>Table 5</i> , Specification F							
C	Refer to <i>Table 4</i> or <i>Table 5</i> , Specification G							
D	2.95 [75]							
E	31.12 [790.5]	31.12 [790.5]	35.65 [905.5]	37.74 [958.5]	43.48 [1104.5]	46.44 [1179.5]	42.54 [1080.5]	53.76 [1365.5]

Table 8

Machine Installation on Floor or Steel Base

The drum of rigid-mount machines is fixed to the frame. The floor and steel base (if used) underneath the machine **MUST** be stable enough to be able to absorb the dynamic loads which are created during the spin sequence. Refer to *General Specifications*. M16 anchor bolts and washers (60mm external diameter, 16.5mm internal diameter, 6mm thickness) and M16 self-locking nuts must be used so the machine, the steel base (if used) and floor form one integral unit. Refer to *Figure 8* and *Figure 9*.

NOTE: Anchor bolts are not supplied with machine. Washers and nuts are supplied with machines. Torque is 100Nm. For anchoring dimensions, refer to *Mounting Bolt Hole Locations*

	<h2>CAUTION</h2>
<p>To avoid installing the machine in such a way that may lead to the machine becoming damaged during operation, be sure to use the nuts and washers supplied with the machine during installation.</p>	

Installation on floor

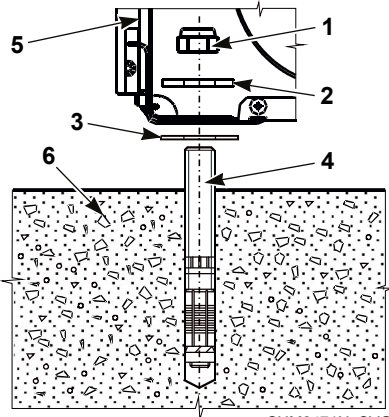

CHM2471N_SVG

1. Nuts M16; supplied with the machine
2. Washers; 60mm external diameter, 16.5mm internal diameter, 6mm thickness; supplied with the machine
3. Spacing washer
4. Anchor bolt
5. Washing machine
6. Concrete floor

Figure 8

Installation on a steel base and floor

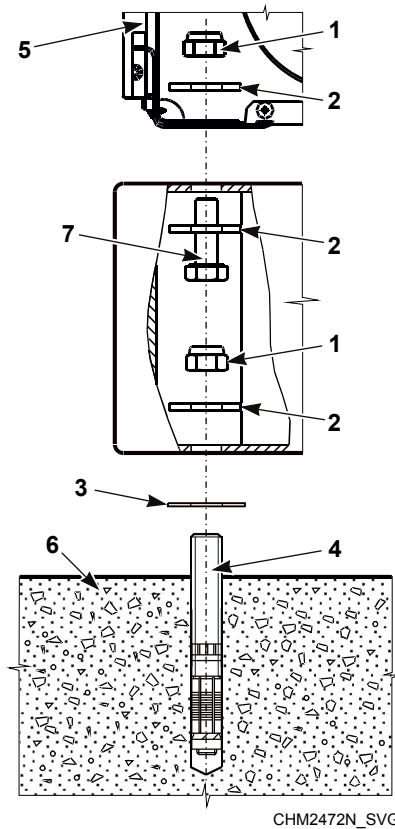

1. Nuts M16; supplied with the machine
2. Washers; 60mm external diameter, 16.5mm internal diameter, 6mm thickness; supplied with the machine
3. Spacing washer
4. Anchor bolt
5. Washing machine
6. Concrete floor
7. Bolt (supplied with steel base)

Figure 9

NOTE: The existing concrete floor must be at least 4.72 in. [120 mm] thick.

1. Check that the machine is installed in a level and stable manner in all its corners.
2. If necessary, level the machine up by means of stainless or galvanized spacing washers inserted between the machine frame and the floor. Refer to *Figure 10* and *Figure 11*. The dimensions of the spacers must be the same as the dimension of the machine frame in the place where the anchor bolts are located (80 x 80 mm).
3. Fit a washer and self-locking nut on the anchor bolt and tighten with a torque wrench to 100Nm.

NOTE: It is advisable to recheck the torque after a short period of machine operation.

4. Using the bottom frame of the machine, lift the whole machine and place over the four drilled holes.
5. Check that the machine is seated in a perfectly level manner.
6. Using mechanical or chemical anchor bolts, mount the machine to the floor or steel base.

NOTE: Mounting bolts are not included with the machine.

7.5 kg / 20 lb. / 80 L, 10.5 kg/ 25 lb. / 105 L and 13.5 kg / 30 lb. / 135 L with 100 G or 175 G Extraction; 18 kg/ 40 lb. / 180 L, 24 kg / 55 lb. / 240 L and 28 kg / 70 lb. / 280 L with 100 G Extraction

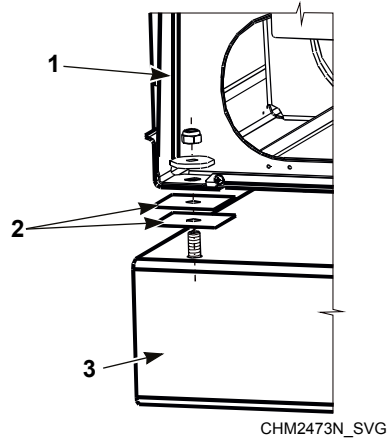

1. Washing machine
2. Spacing washers, as needed
3. Concrete floor

Figure 10

18 kg/ 40 lb. / 180 L, 24 kg / 55 lb. / 240 L and 28 kg / 70 lb. / 280 L with 175 G Extraction; 35 kg / 80 lb. / 332 L with 100 G or 150 G Extraction and 52 kg / 120 lb. / 520 L

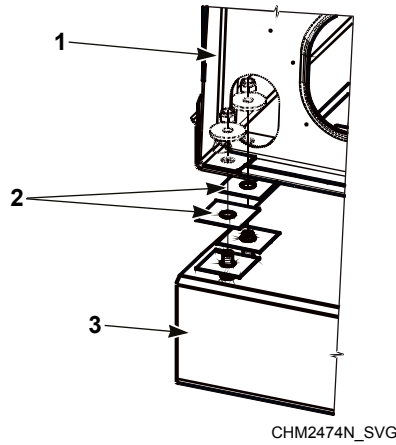

1. Washing machine
2. Spacing washers, as needed
3. Concrete floor

Figure 11

Drain Connection

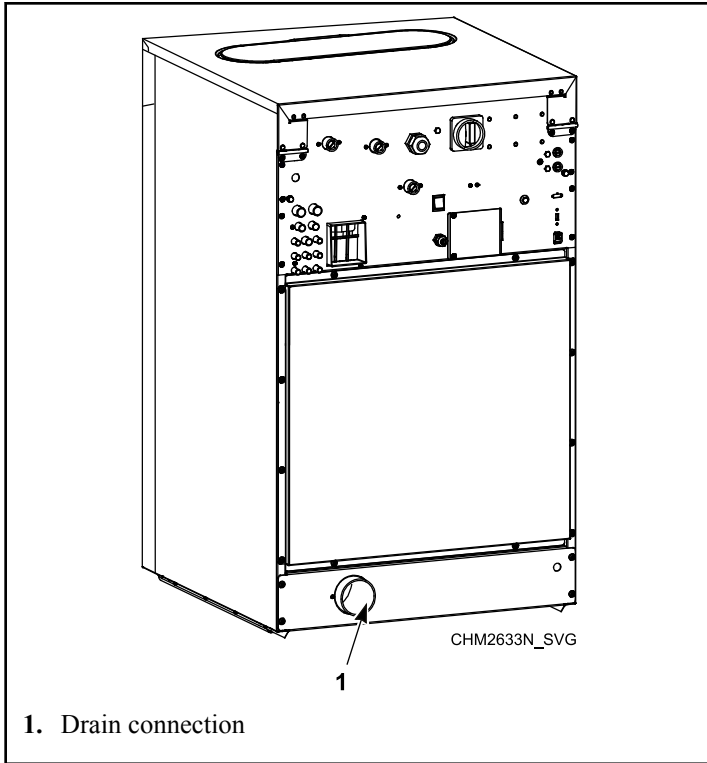

Figure 12

Drain Valve

IMPORTANT: Machine must be installed in accordance with all local codes and ordinances.

All drain systems must be vented to prevent an air lock or siphoning.

Connect a 3 inch [76 mm] pipe or rubber hose to the machine's drain pipe, ensuring a downward flow from the machine. Avoid sharp bends which may prevent proper draining.

The drainage pipe should be located over a floor drain, drainage channel.

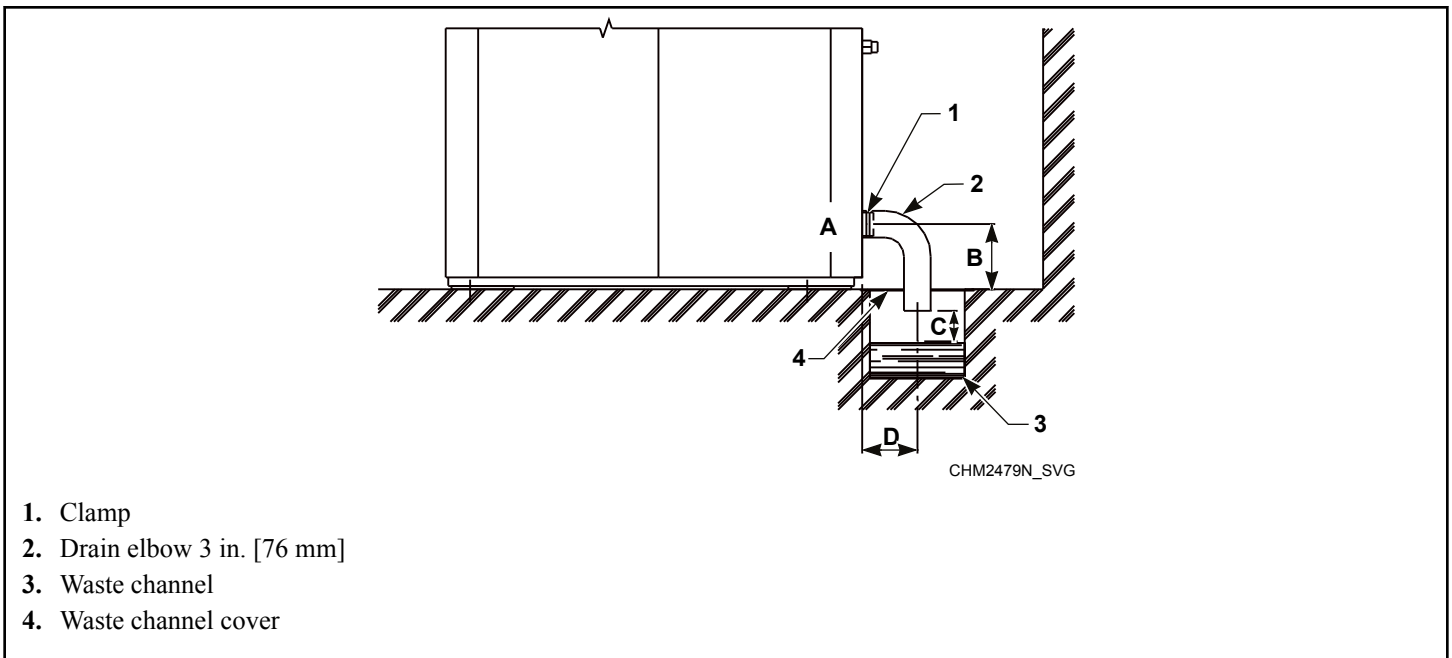

Figure 13

Drainage Pipe Information, in. [mm]								
Specifi- cation	7.5 kg / 20 lb. / 80 L	10.5 kg/ 25 lb. / 105 L	13.5 kg/ 30 lb. / 135 L	18 kg/ 40 lb. / 180 L	24 kg / 55 lb. / 240 L	28 kg / 70 lb. / 280 L	35 kg / 80 lb. / 332 L	52 kg / 120 lb. / 520 L
A	3 [75]	3 [75]	3 [75]	3 [75]	3 [75]	3 [75]	3 [75]	3 [75]
B	3.46 [88]	3.85 [98]	3.95 [98]	5.12 [130]	5.12 [130]	5.12 [130]	4.72 [120]	4.72 [120]
C mini- mum	0.79 [20]	0.79 [20]	0.79 [20]	0.79 [20]	0.79 [20]	0.79 [20]	0.79 [20]	0.79 [20]
D mini- mum	3.94 [100]	3.94 [100]	3.94 [100]	3.94 [100]	3.94 [100]	3.94 [100]	3.94 [100]	3.94 [100]

Table 9

Drain Connections		
Specification	Model	Requirement
Drain connection number	7.5 kg - 28 kg / 20 lb.- 70 lb./ 80 L- 280 L	1
	35 kg - 52 kg / 80 lb.- 120 lb. / 332 L- 520 L	2
Drain connection size, in. [mm]	All	3 [76]
Average flow rate of draining gal/min. [l/min.]	7.5 kg - 28 kg / 20 lb.- 70 lb./ 80 L- 280 L	55.48 [210]
	35 kg - 52 kg / 80 lb.- 120 lb. / 332 L- 520 L	110 [420]
Drain pump with hose - internal diameter of hose, in [mm]	7.5 kg / 20 lb. / 80 L	0.75 [19]
Flow rate of drain pump, gal/min. [l/min.]	7.5 kg / 20 lb. / 80 L	9.51 [36]

Table 10

The main drain channel-pipe must have the capacity to be able to handle the total output of all connected machines. In a drainpipe, a vent must be provided every 65.62 ft. [20 m] to assure the drain pipe will work. If the main drain pipe cannot be sufficiently vented, install a vent per machine. Every time a machine is coupled

on the drainpipe, the diameter of the tube or the width of the waste channel must increase. Refer to *Figure 14*.

The diameters of drain pipe for machines with two drain valves must have dimensions suitable for double the value of water flow.

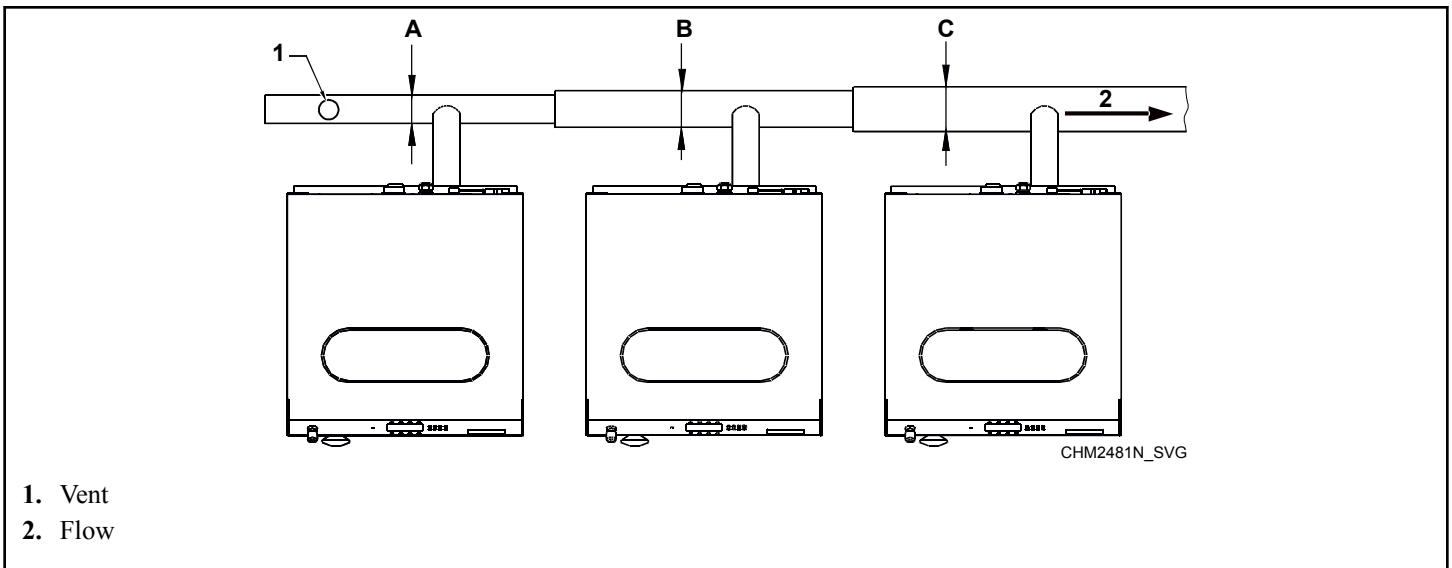

Figure 14

Drain Line Sizing / Minimum Drain ID, in. [mm]		
A - 1 Machine	B - 2 Machines	C - 3 Machines
3 [75]	4 [100]	5 [125]

Table 11

Drain Pump, 7.5 kg / 20 lb. / 80 L Models outside of North America

Connect a flexible hose to a drain pipe so that the hose bend must not be located lower than the water level to provide sufficient siphon effect. In order to achieve good draining, the hose must not bend at a sharp angle. Refer to *Figure 15*.

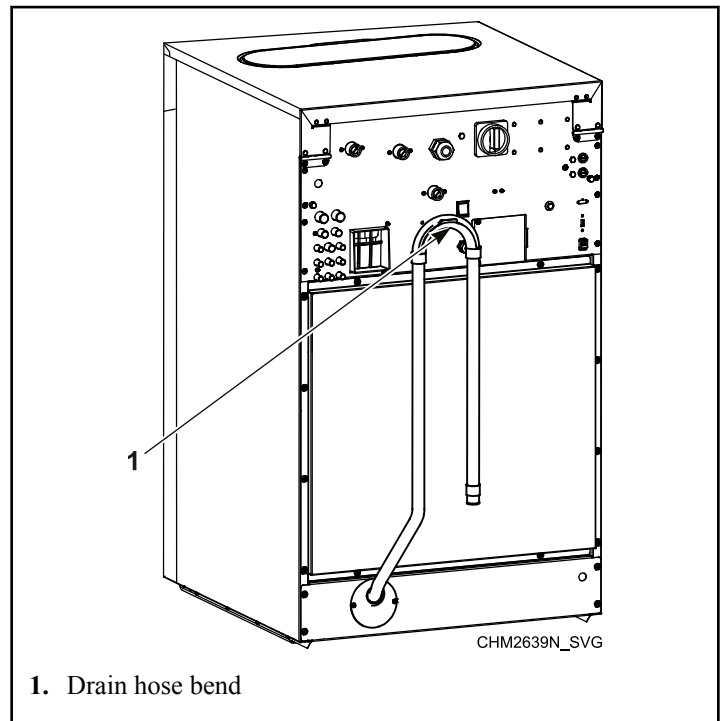

1. Drain hose bend

Figure 15

Water Connection Requirements

	WARNING
<p>To prevent personal injury, avoid contact with inlet water temperatures higher than 125° Fahrenheit [51° Celsius] and hot surfaces.</p>	
W748	

	WARNING
<p>Hot water is used to flush the supply dispenser. Do not open the supply dispenser lid while the machine is running. The discharge or splashing of hazardous liquid can cause serious scalding and burning.</p>	
C377	

NOTE: For HX65, HX80, HX105, HX135, HX180, and HX240 Models, to connect cold water, use a hose with plastic elbow. To connect hot water, use a hose with metal elbow.

Do not re-use water hoses; only use new water hoses.

The appliance has been designed with a built-in "AB" airgap system according to EN1717. Nevertheless, when potable water will be connected to the appliance, a WRAS approved double check valve or some other no less effective device providing backflow prevention protection to at least fluid category three shall be fitted at the point of connections between the water supply and the appliance.

All intake connections to the machine are to be fitted with manual shut-off valves and filters, to facilitate installation and servicing.

All water connectors present on the machine must be connected or the wash program will not function correctly. Refer to *Table 12* for possible connection options, which will depend on the water types to be connected to the machine, which can be found by checking the machine plates.

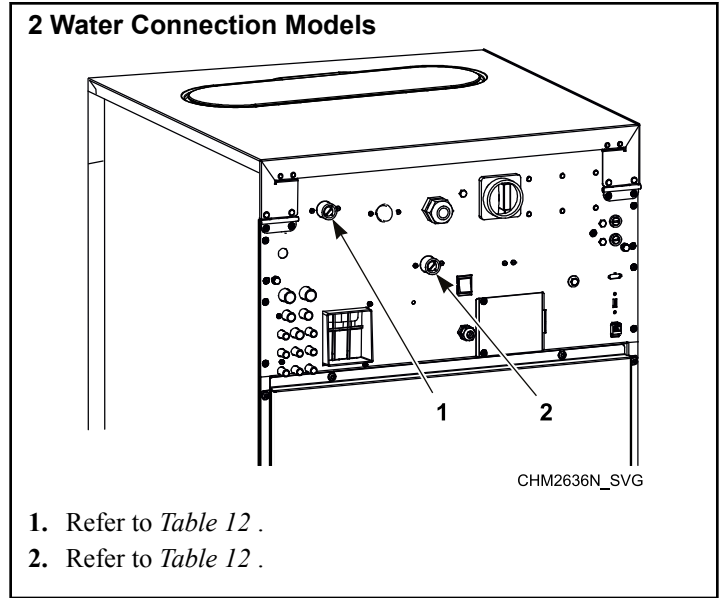

Figure 16

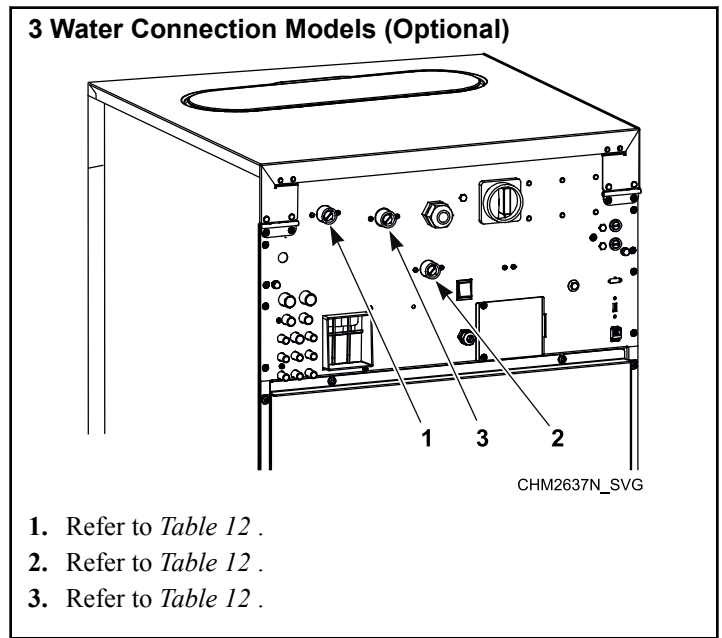



Figure 17

Water type	Water connection		
	1	2	3*
Cold and Hot	Cold	Hot	N/A
Cold soft, Cold hard and Hot	Cold soft	Hot	Cold hard
*Optional			

Table 12

	WARNING
<p>If the water pressure is below the minimum value, the wash result can not be guaranteed for a selected program.</p>	
W914	

The maximum water inlet temperature for vended models is 151°F [66°C] and the maximum water inlet temperature for on-premises models is 194°F [90°C] (models without WRAS approval) or 140°F [60°C] (WRAS approved models).

Connections should be supplied by a hot and a cold water line of at least the sizes shown in Water Supply Line Sizing . Installation of additional machines will require proportionately larger water lines.

Connections should be supplied by a hot and a cold water line per national and local codes and in accordance with IEC 61770.

To connect water service to a machine with hoses, use the following procedure:

1. Before installing hoses, flush the building’s water system at the machine connection valves for at least two (2) minutes.
2. Check filters in the machine’s inlet hoses for proper fit and cleanliness before connecting.
3. Hang hoses in a large loop; do not allow them to kink.

If additional hose lengths are needed or using hoses other than those supplied by manufacturer, flexible hoses with screen filters are required.

Water Connections		
Specification	Model	Requirement
Water inlet connection size, in. BSP	7.5 kg - 35 kg / 20 lb. - 80 lb. / 80 L - 332 L	3/4
	52 kg / 120 lb./ 520 L	1
Recommended pressure, PSI [bar]	All	44-73 [3-5]
Inlet flow capacity per inlet (standard pressure), gal/min [l/min.]	7.5 kg - 24 kg / 20 lb. - 55 lb. / 80 L - 240 L	5.28 [20]
Inlet flow capacity per inlet, gal/min at 60 PSI [l/min. at 4 bar]	18 kg - 35 kg / 40 lb. - 80 lb. / 180 L - 332 L*	34.88 [133]
Inlet flow capacity per inlet, gal/min at 60 PSI [l/min. at 4 bar]	52 kg / 120 lb./ 520 L	96.68 [367]
* 18 kg - 24 kg / 40 lb. - 55 lb. / 180 L - 240 L-optional		

Table 13

Suitable air cushions (risers) should be installed in supply lines to prevent “hammering.”

Alliance Laundry Systems, LLC ranges of front loading commercial clothes washing machines have solenoid valves at the inlets. Minimum and maximum working pressure 1 bar and 8 bar. The machines are supplied with approved inlet hoses.

Installation

Solenoid valves provide machine protection to comply with WRAS (IRN R150), European standard EN1717.



Figure 18

Connecting Hoses

To comply with Australian water regulations and Australian standard AS/NZS3500.1, an approved dual check valve backflow prevention device with the watermark is provided with the unit and must be fitted at the point of connection(s) between the supply and the fitting. Refer to *Figure 20*.



Figure 19

Connections should be supplied by a hot and a cold water line per national and local codes and in accordance with AS/NZS 3500.1.

1. Insert rubber washers and filter screens (from accessories bag) in water fill hose couplings (two hoses supplied with washer). The filter screen must be facing outward.

NOTE: If using hoses with BSPP thread coupling, insert filter screens into the BLACK colored hose couplings and the rubber washers into the brass colored hose couplings.

2. Connect fill hose couplings with filter screens to water supply taps.
3. Connect the other hose couplings to the hot and cold valve connections at the rear of the washer.

NOTE: If using hoses with BSPP thread coupling, connect the BLACK colored hose coupling end of the fill hoses (with filter screens) to the water supply taps. Then connect end of hoses with the brass colored hose couplings to the hot and cold water mixing valve connections at rear of washer.

4. Thread hose couplings onto valve connections finger tight. Then turn 1/4 turn with pliers.

IMPORTANT: DO NOT cross thread or overtighten couplings. This will cause them to leak.

5. Turn water on and check for leaks.
6. If leaks are found, retighten the hose couplings.
7. Continue tightening and rechecking until no leaks are found.

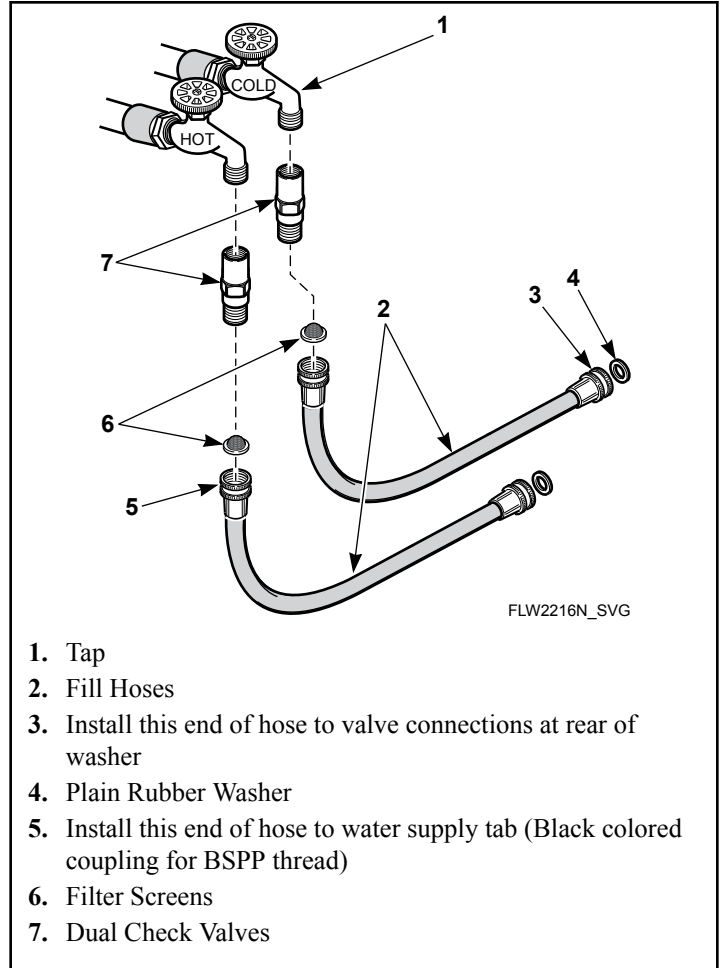



Figure 20

Water Reuse Connection (Optional)

	WARNING
<p>Disconnect the machine power supply. When the main switch is turned off, the inlet terminals of the machine main switch are still under current.</p>	
W900	

1. Drill out the protective screens of the water reuse inlet using a drill bit of 0.59 in. [15 mm] diameter. Refer to *Figure 21*.

IMPORTANT: Do not pierce the screens open. It could lead to blockage of the water channel.

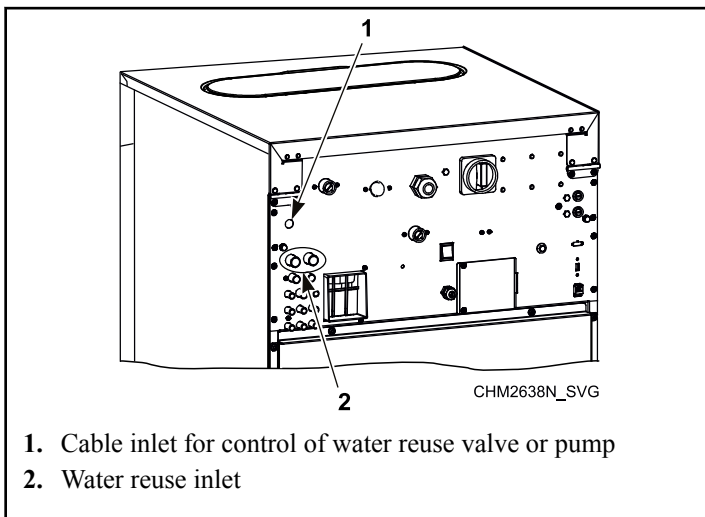

1. Cable inlet for control of water reuse valve or pump
2. Water reuse inlet

Figure 21

2. Connect the control of your reuse valve or pump onto the conductor of inlet valve I5 or I7 provided by the manufacturer, which will disconnect the valve in question from standard function.

IMPORTANT: The manufacturer waives all responsibility for malfunction of the washing machine if a different valve than the specified I5 or I7 is used as the water recycle valve.

3. Fit a cable bushing into the opening, and pull the cable through the bushing. Refer to *Figure 21*.
4. Connect the coil for control of the recuperated water inlet (the coil is not supplied with the machine), operating voltage 208-240V 50/60 Hz.
5. Secure the cable so that it cannot be pulled out of the machine or inlet valve.

Water Reuse Specifications	
Temperature range, °F [°C]	41 to 194 [5 to 90]

Table continues...

Water Reuse Specifications	
Maximum pressure, PSI [bar]	116 [8]
Connection - outside diameter, in. [mm]	0.75 [19]

The hose and the connector must be resistant to chemical substances which are used for the washing process. It is also possible to use a hose with enhanced performance such as the rubber EPDM hose.

The water reuse system must be fitted with a filter which must be regularly and thoroughly cleaned (based on water quality). This cleaning prevents prolongation of filling up times and malfunction of water valves.

Reused Water Treatment

The reused water must be filtered before entering the water reuse tank. A mechanical filter must be installed which filters off small particles (fluff, buttons, paper, etc.) of sizes 0.0079 in. [0.2 mm] or smaller. The denser the mesh, the better. There must also be a filter installed on the pressure side of the pump. It is also possible to install an additional, chemical filter. The manufacturer advises to consult a specialist in filter systems.

Water Reuse Tank Properties

	WARNING
<p>It is prohibited to heat the water in the reuse tank. This would disturb the temperature balance of the washer and make the remaining chemicals in the recuperated water more active, which would lead to corrosion of the entire installation.</p>	
W901	

The reuse tank must meet the following minimum requirements:

- The tank must be made according to national standards.
- Tank capacity varies depending on multiple factors, so it must be calculated by an authorized engineer. The factors are:
 - The number of washing steps per washer, in which the water will be re-used.
 - The programmable amount of water that will be re-used in a washing step (to find this amount, please refer to the Programming Manual).
 - The number of washers that will deliver water to the reuse tank.
 - The use of recuperated water per washer.

The tank must have an overflow to the sewer. Water from the sewer must not be able to flow back into the reuse tank.

WARNING

Grounding: In event of malfunction, breakdown or leakage current, grounding will reduce the risk of electrical shock and serve as a protecting device by providing a path of least resistance of electrical current. Therefore, it is very important and the responsibility of the installer to assure the washer is adequately grounded at installation, following all national and local requirements.

W902

Current Interrupter (ALCI) or Earth (Ground) Leakage Current Breaker.

When locally allowed, an RCD must be installed. In some power network earthing systems, an RCD may not be allowed.

The RCD must have the following specifications:

- Tripping current of 100mA (if not locally available/allowed, use a 30mA trip current, preferably selective type with small time delay set)
- Type B (components inside the machine which make use of DC voltages and require this better performance RCD)
- Maximum of 2 machines installed on each RCD (for 30mA, only 1 machine)

Some washer control circuits are supplied with a separating transformer. Therefore, the RCD may not detect faults in the control circuits (but the fuse(s) on the separating transformer will).

Supply Protection Device

A supply protection device protects the machine and wiring against short circuits. (Glow-wire) fuses or (automatic) circuit breakers may be used as supply protection devices.

Protection must be the "slow" type, which means curve D for circuit breakers.

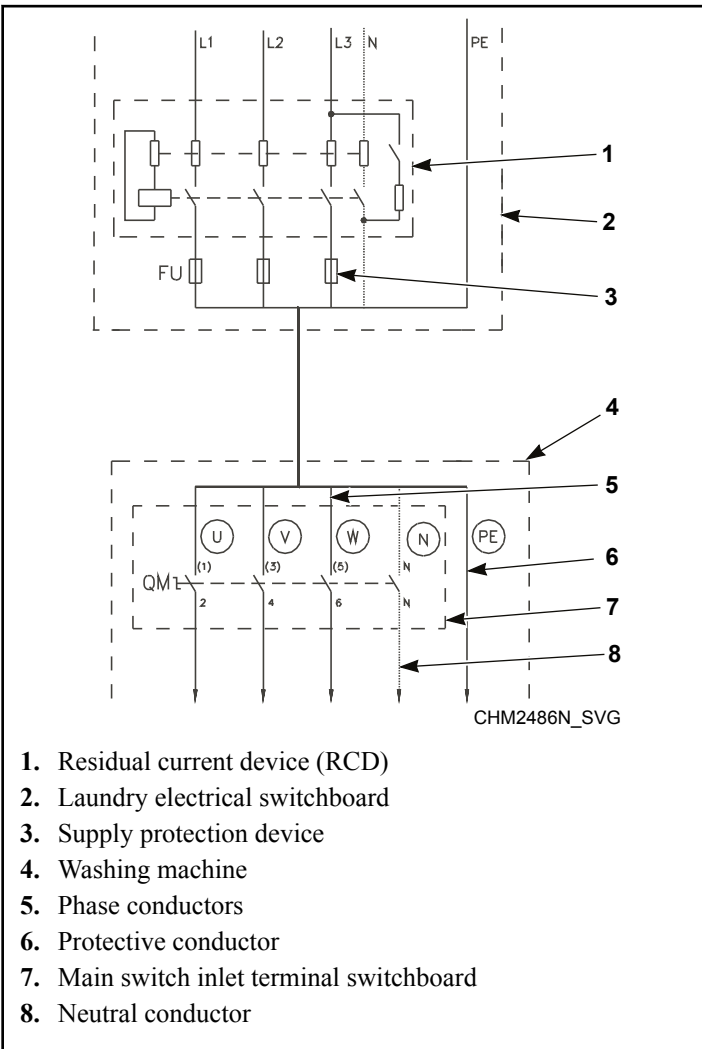

Figure 23

IMPORTANT: Alliance Laundry Systems warranty does not cover components that fail as a result of improper input voltage.

Residual Current Device (RCD)

In some countries, an RCD is known as an Earth Leakage Trip, Ground Fault Circuit Interrupter (GFCI), Appliance Leakage

Supply Cable

The supply cable is not delivered with the machine. The supply cable must have the following specifications:

The supply cable is delivered with the machine. If the supply cable needs to be replaced, the new cable must have the following specifications:

- Conductors with copper cores (For wire size details, refer to *Electrical Specifications*)

Determining AWG Sizes

Power supply protection device nominal current		Min. phase conductor section, AWG [mm ²]	Min. protection conductor section, AWG [mm ²]
Automatic circuit breakers	Fuses		
16A (15A)	10A (10A)	15 [1.5]	15 [1.5]
20A (20A)	16A (15A)	13 [2.5]	13 [2.5]
25A (-)	20A (20A)	11 [4]	11 [4]
40A (40A)	32A (30A)	9 [6]	9 [6]
63A (-)	50A (50A)	7 [10]	7 [10]
80A	63A	5 [16]	5 [16]
100A	80A	3 [25]	5 [16]
125A	100A	2 [35]	3 [25]

Table 14

To connect the supply cable, the following steps must be performed:

1. Insert cable through opening on rear panel. Insure a strain relief is used so the supply cable can not move.
2. Strip the conductor ends. Refer to *Figure 24* . The protection conductor must be longer so it can be routed to the machine without tension.

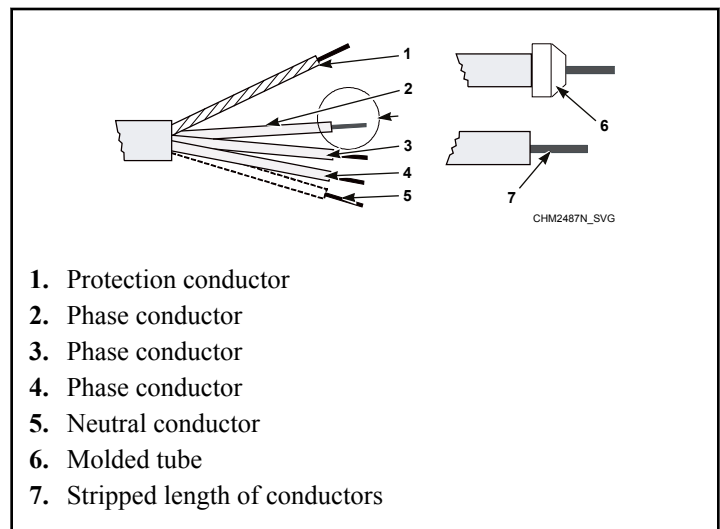

Figure 24

3. With stranded conductors, use wire end tubes with an insulated sleeve (6) for L1/U, (L2/V), (L3/W), (N) conductors.

Make sure there is no accidental contact, since the supply cable stays under voltage even when the main switch is off.

4. Crimp a ring terminal to the protection conductor so it stays fixed to the PE terminal.
5. Connect the supply cable conductors to the incoming terminals (main switch [1]), marked with L1/U, (L2/V), (L3/W), (N) and the terminal marked with PE. Refer to *Figure 25*.
6. Provide a sag in the cable, in front of the strain relief. This will prevent condensed water from dripping into the machine. Refer to *Figure 25*.

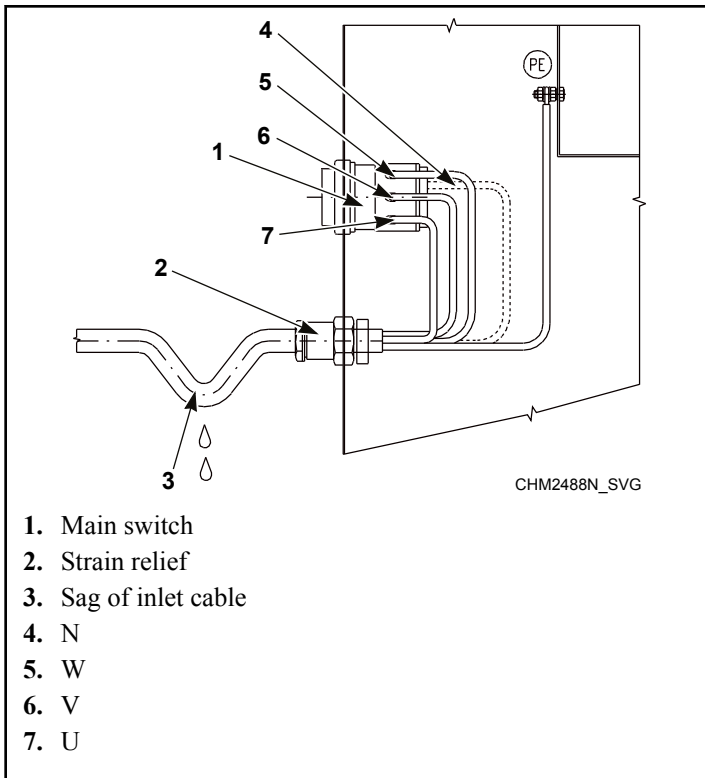

Figure 25

Machine Protective Earth Connection and Equipotential Bonding

If there are other washers or appliances with exposed conductive parts, which can touch simultaneously, make sure to make equipotential bonding between all these appliances. The external protective terminal for this purpose is located on the rear panel of the machine frame. The minimum protection conductor's cross section depends on the supply cable cross section (refer to *Table 14*). However, for the protection purposes, with the supply cable cross section of a min. 4 mm², select a larger conductor section, i.e., 6 mm².

Input Power Conditioning

The drive is suitable for direct connection to input power within the rated voltage of the drive. Listed in *Input Power Condition* are certain input power conditions which may cause component damage or reduction in product life. If any of the conditions exist,

install one of the devices listed under the Possible Corrective Action(s).

IMPORTANT: Only one device per branch circuit is required. It should be mounted closest to the branch and sized to handle the total current of the branch circuit.

Input Power Condition	Possible Corrective Action(s)
Low Line impedance (less than 1% line reactance)	<ul style="list-style-type: none"> • Install Line Reactor • Isolation Transformer
Greater than 120 kVA supply transformer	
Line has power factor correction capacitors	<ul style="list-style-type: none"> • Install Line Reactor • Isolation Transformer
Line has frequent power interruptions	
Line has intermittent noise spikes in excess of 6000V (lightning)	
Phase to ground voltage exceeds 125% of normal line to line voltage	<ul style="list-style-type: none"> • Remove MOV jumper to ground • Install Isolation Transformer with grounded secondary (if necessary)
Ungrounded distribution system	
240V open delta configuration (stinger leg)*	<ul style="list-style-type: none"> • Install Line Reactor
<p>* For drives applied on an open delta with a middle phase grounded neutral system, the phase opposite the phase that is tapped in the middle to the neutral or earth is referred to as the “stinger leg,” “high leg,” “red leg,” etc. This leg should be identified throughout the system with red or orange tape on the wire at each connection point. The stinger leg should be connected to the center Phase B on the reactor.</p>	

Table 15

Input Voltage Requirements

For voltages above or below listed specifications, contact your power company or local electrician.

If machine is intended for four-wire service, a neutral leg must be provided by power company.

If a delta supply system is used on a four-wire model, connect high leg to L3.

IMPORTANT: Improper connections will result in equipment damage and will void warranty.

	DANGER
<p>Electrical shock hazard will result in death or serious injury. Disconnect electric power and wait five (5) minutes before servicing.</p>	
W810	

	DANGER
<p>Hazardous Rotation Speed. Will cause serious injury when controlling AC inverter drive with a parameter unit, safety features are bypassed allowing basket to rotate at high speeds with the door open. Place large sign on front of machine to warn people of imminent danger.</p>	
W361	

Circuit Breakers and Quick Disconnects

Single-phase machines require a single-phase inverse-time circuit breaker. Three-phase machines require a separate, three-phase inverse-time circuit breaker to prevent damage to the motor by disconnecting all legs if one should be lost accidentally. Refer to section for model-specific circuit breaker requirements.

IMPORTANT: All quick disconnects should comply with the specifications. DO NOT use fuses instead of circuit breakers.

Connection Specifications

IMPORTANT: Connection must be made by a qualified electrician using wiring diagram provided with machine, or according to accepted European Union standards.

Connect machine to an individual branch circuit not shared with lighting or other equipment. Shield connection in a liquid-tight or approved flexible conduit. Copper conductors of correct size must be installed in accordance with National Electric Code (NEC) or other applicable codes.

Use wire sizes indicated in the Electrical Specifications chart for runs up to 50 feet [15 m]. Use next larger size for runs of 50 to 100 feet [15 to 30 m]. Use two (2) sizes larger for runs greater than 100 feet [30 m].

Single Phase Connection

Connect the electrical service's wires to the machine's electrical connection terminal as shown.

Electrical Service Wire	Machine's Electrical Connection Terminal
U	U
Neutral	N
PE	PE (Ground)

Table 16

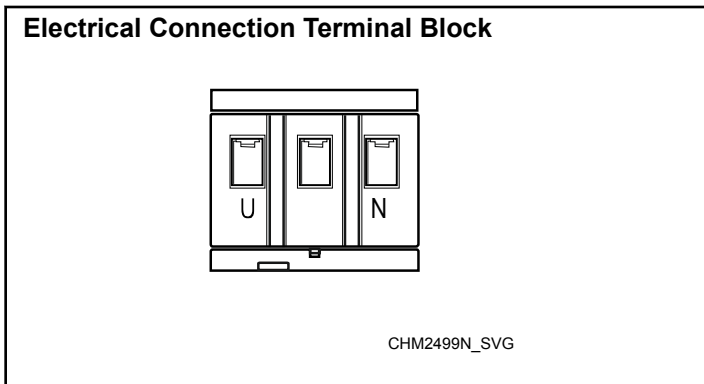

Figure 26

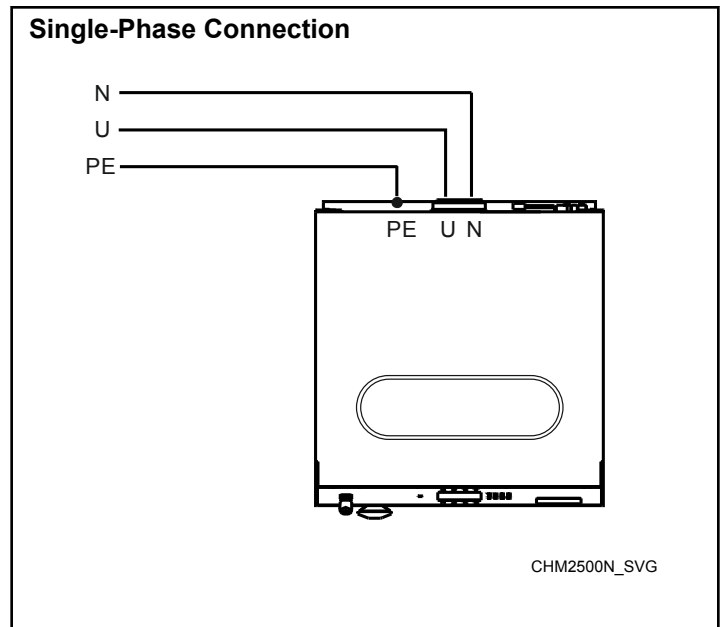

Figure 27

Three Phase Connection

Connect the electrical service's wires to the machine's electrical connection terminal as shown.

Electrical Service Wire	Machine's Electrical Connection Terminal
U	U
V	V
W	W
PE	PE (Ground)
Neutral	N

Table 17

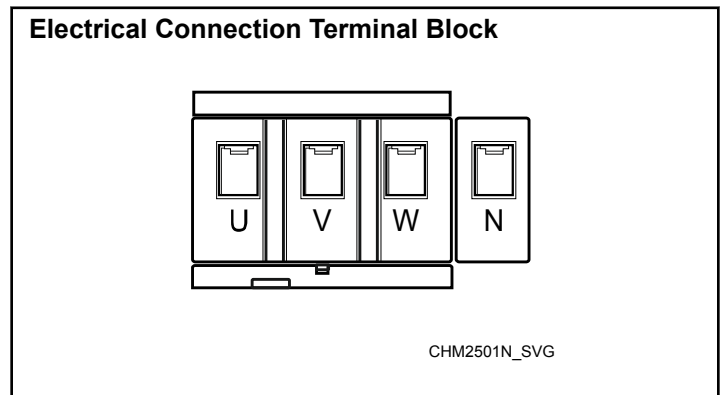

Figure 28

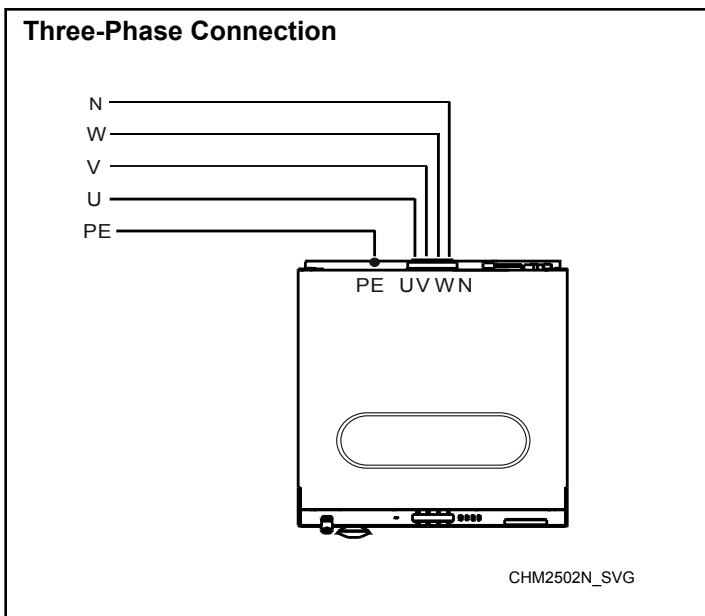

Figure 29

If the frequency required at installation is different than the default setting, redirect the voltage wire to the appropriate frequency terminal at the drain valve.

Thermal Overload Protector

For models with inverter drives, the inverter drive provides overload protection for the drive motor.

Phase Adder

Machines can be converted for lower voltage operation and/or 50 Hz operation. Refer to conversion label by serial plate for details.

IMPORTANT: Do not use a phase adder on any machine.

Voltage Settings

The machines are designed and manufactured for a voltage range. Refer to the serial plate for voltage range information specific to your machine.

Make sure the supply voltage is always within the limits specified.

When a transformer is provided (control or step down transformer), it is set to the highest voltage of the range at the manufacturing facility. If, at installation, the nominal supply voltage is lower, the appropriate voltage terminal on the transformer must be selected. For example, if the voltage range is 208-240V, the connected terminal transformer will be 240V. If the supply voltage is 208V, redirect the voltage wire to the 208V terminal.

Frequency Settings

The machines are designed and manufactured for 50/60HZ. Refer to the serial plate for frequency information specific to your machine.

Make sure the frequency is always within the limits specified.

When a gravity drain is provided (no pump execution), the factory setting for the drain valve is 60Hz for North American models and 50Hz for models outside of North America.

Electrical Specifications

7.5 kg / 20 lb. / 80 L Models

Voltage (V)	Frequency (Hz)	Phase	Wire	Standard			Electric Heat		
				Total Power (kW)	Full Load Amps (A)	Fuse (A)	Total Power (kW)	Full Load Amps (Electric Heating kW)	Fuse (A)
120	60	1	2	0.6	8	10	N/A	N/A	N/A
200-240	50/60	1	2 (L1, L2, or L1, N)	0.6	4.4	10	3.4	17 (3)	20
							5	24 (4.6)	32
200-240	50/60	3	3 (L1, L2, L3)	0.6	4.4	10	6.5	19.1 (6)	25
							9.5	26.5 (9)	32
380-415 + N	50/60	3	4 (L1, L2, L3, N)	0.6	4.4	10	5.1	10 (4.6)	16
							6.5	12.6 (6)	16
							9.5	17 (9)	20
380-415	50/60	3	3 (L1, L2, L3)	0.6	2.6	10	6.5	11.7 (6)	16
							9.5	16.2 (9)	20
440-480	50/60	3	3 (L1, L2, L3)	0.6	2.6	10	7.5	13.5 (7)	16
							9.5	15.5 (9)	16

Table 18

10.5 kg / 25 lb. / 105 L Models

Voltage (V)	Frequency (Hz)	Phase	Wire	Standard			Electric Heat		
				Total Power (kW)	Full Load Amps (A)	Fuse (A)	Total Power (kW)	Full Load Amps (Electric Heating kW)	Fuse (A)
120	60	1	2	0.65	11.7	16	N/A	N/A	N/A
200-240	50/60	1	2 (L1, L2, or L1, N)	0.65	6.3	10	3.5	17.5 (3)	20
							5.1	25 (4.6)	32
200-240	50/60	3	3 (L1, L2, L3)	0.65	6.3	10	6.6	20.1 (6)	25
							9.6	27.6 (9)	32
							12.6	35.2 (12)	40
380-415 + N	50/60	3	4 (L1, L2, L3, N)	0.65	6.3	10	6.6	12.5 (6)	16
							9.6	17.5 (9)	20
							12.6	22.4 (12)	25
380-415	50/60	3	3 (L1, L2, L3)	0.65	3.7	10	6.6	12.6 (6)	16
							9.6	17 (9)	20
							12.6	21.3 (12)	25
440-480	50/60	3	3 (L1, L2, L3)	0.65	3.7	10	7.6	12.3 (7)	16
							9.6	15.7 (9)	16
							12.6	20 (12)	25

Table 19

13.5 kg / 30 lb. / 135 L Models

Voltage (V)	Frequency (Hz)	Phase	Wire	Standard			Electric Heat		
				Total Power (kW)	Full Load Amps (A)	Fuse (A)	Total Power (kW)	Full Load Amps (Electric Heating kW)	Fuse (A)
120	60	1	2	0.85	13.3	20	N/A	N/A	N/A
200-240	50/60	1	2 (L1, L2, or L1, N)	0.85	7.2	10	3.9	18.8 (3)	20
							5.5	25.8 (4.6)	32
380-415 + N	50/60	3	3 (L1, L2, L3)	0.85	7.2	10	6.8	19 (6)	25
200-240	50/60	3	3 (L1, L2, L3)	N/A	N/A	N/A	9.8	28.5 (9)	32
							12.8	36 (12)	40
380-415 + N	50/60	3	4 (L1, L2, L3, N)	0.85	7.2	10	6.8	12 (6)	16
							9.8	17.6 (9)	20
							12.8	22.5 (12)	25
380-415	50/60	3	3 (L1, L2, L3)	0.85	4.2	10	6.8	12.9 (6)	16
							9.8	17.2 (9)	20
							12.8	21.5 (12)	25
							14.6	13.8 (22.5)	32
440-480	50/60	3	3 (L1, L2, L3)	0.85	4.2	10	7.8	12.2 (7)	16
							9.8	15.9 (9)	16
							12.8	20 (12)	25

Table 20

18 kg / 40 lb. / 180 L Models (100G)

Voltage (V)	Frequency (Hz)	Phase	Wire	Standard			Electric Heat		
				Total Power (kW)	Full Load Amps (A)	Fuse (A)	Total Power (kW)	Full Load Amps (Electric Heating kW)	Fuse (A)
200-240	50/60	1	2 (L1, L2, or L1, N)	0.85	7.4	10	N/A	N/A	N/A
200-240	50/60	3	3 (L1, L2, L3)	0.85	7.4	10	12.7	36 (12)	40
							18.7	51.2 (18)	63
380-415 + N	50/60	3	4 (L1, L2, L3, N)	0.85	7.4	10	12.7	23.3 (12)	25
							18.7	31 (18)	32
380-415	50/60	3	3 (L1, L2, L3)	0.85	3.1	10	12.7	20.5 (12)	25
							18.7	29.5 (18)	32
440-480	50/60	3	3 (L1, L2, L3)	0.85	3.1	10	12.7	19.2 (12)	25
							18.7	27.2 (18)	32

Table 21

18 kg / 40 lb. / 180 L Models (175G)

Voltage (V)	Frequency (Hz)	Phase	Wire	Standard			Electric Heat		
				Total Power (kW)	Full Load Amps (A)	Fuse (A)	Total Power (kW)	Full Load Amps (Electric Heating kW)	Fuse (A)
200-240	50/60	1	2 (L1, L2, or L1, N)	1.2	9.1	16	N/A	N/A	N/A
200-240	50/60	3	3 (L1, L2, L3)	1.2	9.1	16	12.9	36.2 (12)	40
							18.9	53 (18)	63

Table 22 continues...

Voltage (V)	Frequency (Hz)	Phase	Wire	Standard			Electric Heat		
				Total Power (kW)	Full Load Amps (A)	Fuse (A)	Total Power (kW)	Full Load Amps (Electric Heating kW)	Fuse (A)
380-415 + N	50/60	3	4 (L1, L2, L3, N)	1.2	9.1	16	12.9	23.5 (12)	25
							18.9	31 (18)	32
380-415	50/60	3	3 (L1, L2, L3)	1.2	3.3	10	12.9	20.7 (12)	25
							18.9	29.7 (18)	32
440-480	50/60	3	3 (L1, L2, L3)	1.2	3.3	10	12.9	19.4 (12)	25
							18.9	27.4 (18)	32

Table 22

24 kg / 55 lb. / 240 L Models (100G)

Voltage (V)	Frequency (Hz)	Phase	Wire	Standard			Electric Heat		
				Total Power (kW)	Full Load Amps (A)	Fuse (A)	Total Power (kW)	Full Load Amps (Electric Heating kW)	Fuse (A)
200-240	50/60	1	2 (L1, L2, or L1, N)	1.2	9.1	16	N/A	N/A	N/A
200-240	50/60	3	3 (L1, L2, L3)	1.2	9.1	16	19	53 (18)	63
380-415 + N	50/60	3	4 (L1, L2, L3, N)	1.2	9.1	16	19	31.7 (18)	32
380-415	50/60	3	3 (L1, L2, L3)	1.2	3.3	10	19	30 (18)	32
440-480	50/60	3	3 (L1, L2, L3)	1.2	3.3	10	19	28 (18)	32

Table 23

24 kg / 55 lb. / 240 L Models (175G)

Voltage (V)	Frequency (Hz)	Phase	Wire	Standard			Electric Heat		
				Total Power (kW)	Full Load Amps (A)	Fuse (A)	Total Power (kW)	Full Load Amps (Electric Heating kW)	Fuse (A)
200-240	50/60	1	2 (L1, L2, or L1, N)	1.6	9.2	16	N/A	N/A	N/A
200-240	50/60	3	3 (L1, L2, L3)	1.6	9.2	16	19	53 (18)	63
380-415 + N	50/60	3	4 (L1, L2, L3, N)	1.5	9.2	16	19	31.7 (18)	32

Table 24 continues...

Voltage (V)	Frequency (Hz)	Phase	Wire	Standard			Electric Heat		
				Total Power (kW)	Full Load Amps (A)	Fuse (A)	Total Power (kW)	Full Load Amps (Electric Heating kW)	Fuse (A)
380-415	50/60	3	3 (L1, L2, L3)	1.5	3.4	10	19	30 (18)	32
440-480	50/60	3	3 (L1, L2, L3)	1.5	3.4	10	19	28 (18)	32

Table 24

28 kg / 70 lb. / 280 L Models (100G)

Voltage (V)	Frequency (Hz)	Phase	Wire	Standard			Electric Heat		
				Total Power (kW)	Full Load Amps (A)	Fuse (A)	Total Power (kW)	Full Load Amps (Electric Heating kW)	Fuse (A)
200-240	50/60	1	2 (L1, L2, or L1, N)	1.6	9.8	16	N/A	N/A	N/A
200-240	50/60	3	3 (L1, L2, L3)	1.6	9.8	16	19.3	51.2 (18)	63
							23.2	61 (21.9)	63
380-415 + N	50/60	3	4 (L1, L2, L3, N)	1.6	9.8	16	19.3	31.9 (18)	32
							23.2	37.6 (21.9)	40
380-415	50/60	3	3 (L1, L2, L3)	1.6	3.6	10	19.3	30 (18)	32
							23.2	38 (21.9)	40
440-480	50/60	3	3 (L1, L2, L3)	1.6	3.6	10	19.3	29 (18)	32
							23.2	35 (21.9)	32

Table 25

Installation

28 kg / 70 lb. / 280 L Models (175G)

Voltage (V)	Frequency (Hz)	Phase	Wire	Standard			Electric Heat		
				Total Power (kW)	Full Load Amps (A)	Fuse (A)	Total Power (kW)	Full Load Amps (Electric Heating kW)	Fuse (A)
200-240	50/60	1	2 (L1, L2, or L1, N)	1.6	9.9	16	N/A	N/A	N/A
200-240	50/60	3	3 (L1, L2, L3)	1.6	9.9	16	19.3	51.2 (18)	63
							23.2	61 (21.9)	63
380-415 + N	50/60	3	4 (L1, L2, L3, N)	1.6	9.9	16	19.3	31.9 (18)	32
							23.2	37.6 (21.9)	40
380-415	50/60	3	3 (L1, L2, L3)	1.6	3.7	10	19.3	30 (18)	32
							23.2	38 (21.9)	40
440-480	50/60	3	3 (L1, L2, L3)	1.6	3.7	10	19.3	29 (18)	32
							23.2	35 (21.9)	32

Table 26

35 kg / 80 lb. / 332 L Models

Voltage (V)	Frequency (Hz)	Phase	Wire	Standard			Electric Heat		
				Total Power (kW)	Full Load Amps (A)	Fuse (A)	Total Power (kW)	Full Load Amps (Electric Heating kW)	Fuse (A)
200-240	50/60	1	2 (L1, L2 or L1, N)	2.3	16	20	N/A	N/A	N/A
200-240	50/60	3	3 (L1, L2, L3)	2.3	16	20	28.5	76.8 (27)	80
380-415 + N	50/60	3	4 (L1, L2, L3, N)	2.3	16	20	28.5	48.1 (27)	63
380-415	50/60	3	3 (L1, L2, L3)	2.3	8.2	16	28.5	43.5 (27)	50
440-480	50/60	3	3 (L1, L2, L3)	2.3	8.2	16	28.5	51.9 (27)	63

Table 27

52 kg / 120 lb. / 520 L Models

Voltage (V)	Frequency (Hz)	Phase	Wire	Standard			Electric Heat		
				Total Power (kW)	Full Load Amps (A)	Fuse (A)	Total Power (kW)	Full Load Amps (Electric Heating kW)	Fuse (A)
200-240	50/60	1	2 (L1, L2 or L1, N)	4.1	25	32	N/A	N/A	N/A
200-240	50/60	3	3 (L1, L2, L3)	4.1	16.5	20	43	109 (40.6)	125
380-415	50/60	3	3 (L1, L2, L3)	4.1	9.6	16	43	62.9 (40.6)	80

Table 28 continues...

Voltage (V)	Frequency (Hz)	Phase	Wire	Standard			Electric Heat		
				Total Power (kW)	Full Load Amps (A)	Fuse (A)	Total Power (kW)	Full Load Amps (Electric Heating kW)	Fuse (A)
440-480	50/60	3	3 (L1, L2, L3)	4.1	9.6	16	43	81.5 (40.6)	100

Table 28

Steam Requirements (Steam Heat Option Only)

IMPORTANT: Failure to install the customer supplied steam filter may void the warranty.

Use an inlet steam pressure hose only adapted to the steam valve with appropriate seal suitable for the applied working pressure.

Steam Valve Installation

1. Remove the rear cover.
2. Fit the bracket with the steam valve and filter onto the rear part of machine.

	WARNING
<p>Hot Surfaces. Will cause severe burns. Turn steam off and allow steam pipes, connections and components to cool before touching.</p>	
W505	

For machines equipped with optional steam heat, install piping in accordance with approved commercial steam practices. Steam requirements are shown in *Table 29*.

Specification	Model	Requirement
Steam inlet connection size, in. BSP	7.5 kg - 28 kg / 20 lb.- 70 lb./ 80 L- 280 L	1/2
	35 kg - 52 kg / 80 lb.- 120 lb. / 332 L- 520 L	3/4
Steam pressure, PSI [bar]	All	15-116 [1-8]

Table 29

IMPORTANT: It is necessary to insert a filter with permeability up to 0.0118 in. [300 µm] in front of the steam valve. Dirt larger than 0.0118 in. [300 µm] may damage the steam valve and cause leaks.

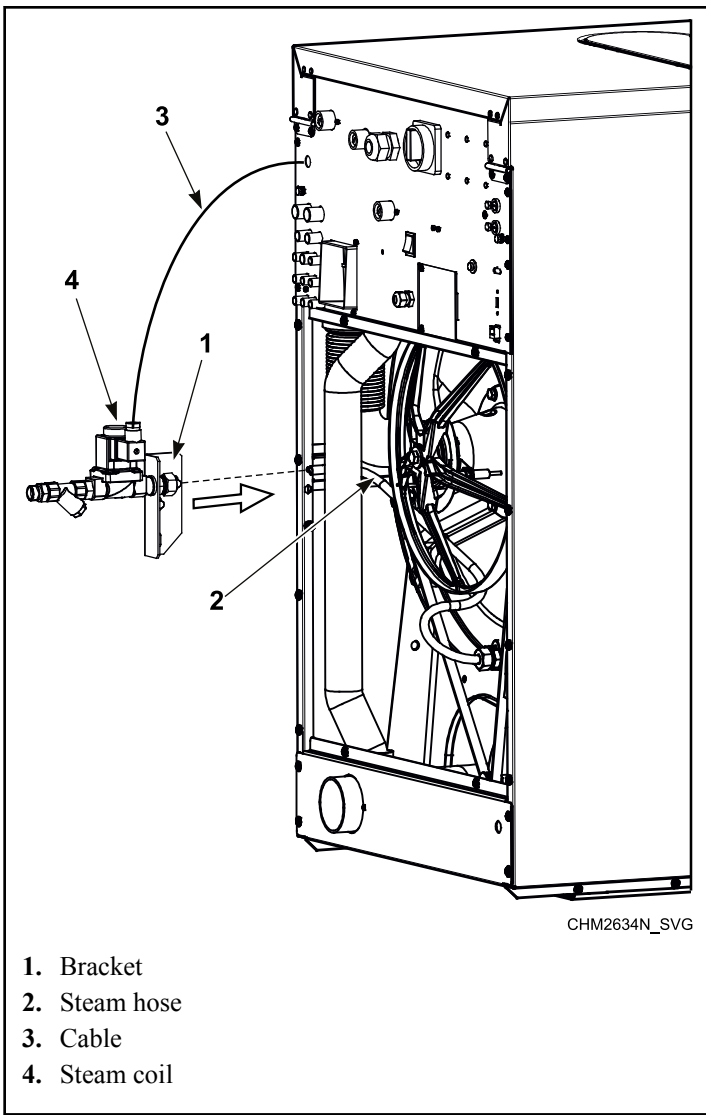

- 1. Bracket
- 2. Steam hose
- 3. Cable
- 4. Steam coil

Figure 30

- 3. Connect steam hose to steam valve.
- 4. Connect the cable to the steam coil.
- 5. Fit rear cover back to its original place.

Supply Dispensing

	WARNING
<p>Dangerous Chemicals. May damage eyes and skin. Wear eye and hand protection when handling chemicals; always avoid direct contact with raw chemicals. Read the manufacturer's directions for accidental contact before handling chemicals. Ensure an eye-rinse facility and an emergency shower are within easy reach. Check at regular intervals for chemical leaks.</p>	
W363	

Supply Dispensing	
Number of external liquid supply connections	8
Liquid supply connection size, in. [mm]	5/16 [8]
Number of diluted liquid soap supply connections	3
Diluted liquid soap supply connection size, in. [mm]	7/16 [11.5]

Table 30

IMPORTANT: Always use liquid soap pumps with a flow that bring the requested quantity in less than 30 sec.

IMPORTANT: Start pumping immediately after water valves are open. The incoming water dilutes the liquid soap and brings it into the tub assembly.

Secure the location of the wiring and hoses so they can not be pinched, damaged or rubbed. Before you start to use liquid soap, check with your liquid soap supplier whether the liquid soap is harmless and inert to PP and PVC material in order to avoid damage to machine.

IMPORTANT: Failure to follow these instructions could damage the machine and void the warranty.

Connection of External Liquid Supplies

- 1. Facing the rear of the machine, locate the eight (8) 5/16 inch [8 mm] supply hose connections found on the left-hand side of the valve panel. Refer to *Figure 31*.

NOTE: Recommended setting of the pump's flow rate is 60 to 100 liters per hour.

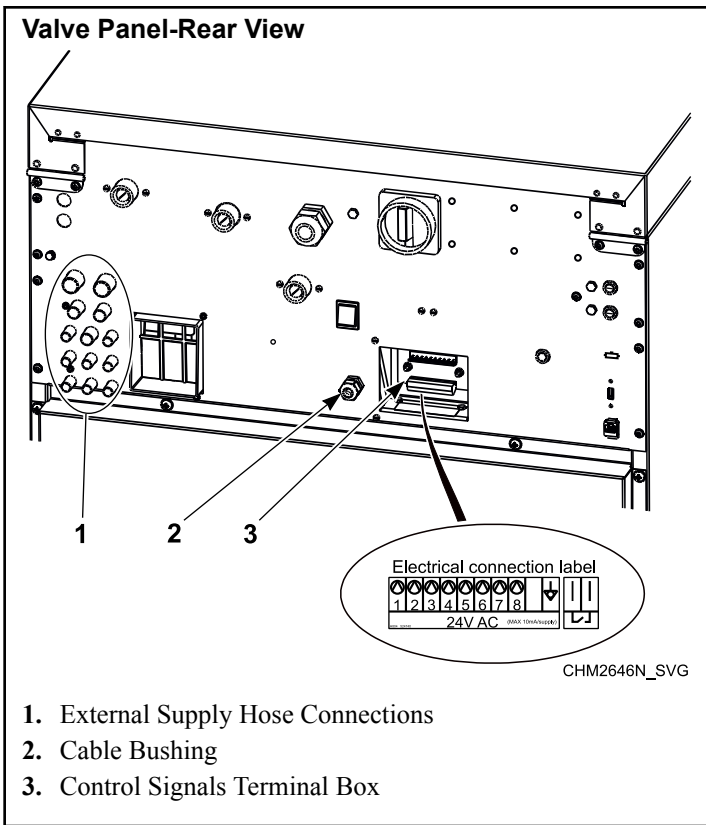

Figure 31

2. Drill through the eight (8) plastic holes on the valve panel for the external supply hoses as needed.

NOTE: On the valve panel by the external supply hose connections are three (3) connections of 1/2 in. 12 mm that are to be used only for entering diluted soap. To use, drill a 7/16 inch 11.5 mm hole only in connections that will be used.

3. Remove plastic debris.
4. Attach the external supply hoses to the ports at each of the drilled holes.
5. Secure with proper clamps.

	WARNING
<p>Check that the hose connections are tight (check the clamps). Any chemical leakage may cause serious bodily injuries as well as serious damage to the washer. If one of the connections is open, close and secure the opening with an appropriate cover.</p>	
W909	

NOTE: Do not attempt to make chemical injection supply pump electrical connections to points other than those provided specifically for that purpose by the factory.

Electrical Connection of External Liquid Soap Supply System

The power supply of the external liquid soap supply system has to be connected to an external electrical source. Only authorized workers with valid qualifications must execute the electrical connection on the machine according to valid local standards. The correction connection can be found on the wiring diagram included with the machine. Do not connect the liquid soap pump system in the washer.

The electric connection for supply control signals is available on the rear panel. Refer to *Figure 31*. At the terminal box, there is a label for electric connection. Detail on connection of signals can also be found on the electric scheme of the machine.

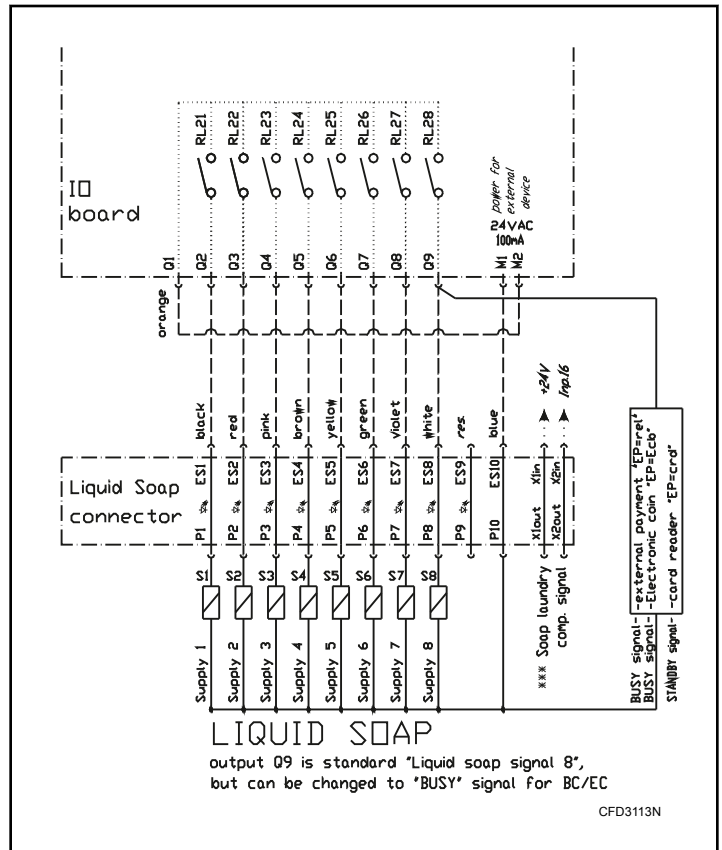

Figure 32

Signals for supply pump control are 24 VAC. Maximum current for control circuits of pump must be limited to 100mA. Lead the cable for connection of pump control signals through the plastic cable bushing. After connection of conductors to the respective positions of the connector "P", fix up the cable by tightening the cable bushing against disconnections and close the box with the cover. For details about liquid soap supply system programming, refer to Programming Manual.

External Wait Control

This function can be activated by an external contact which is connected between the pins ↑ and ↓. Refer to *Figure 33*. Such connection is possible only with machines which had been ordered with the "Heating Delay / Waiting for Detergent" option.

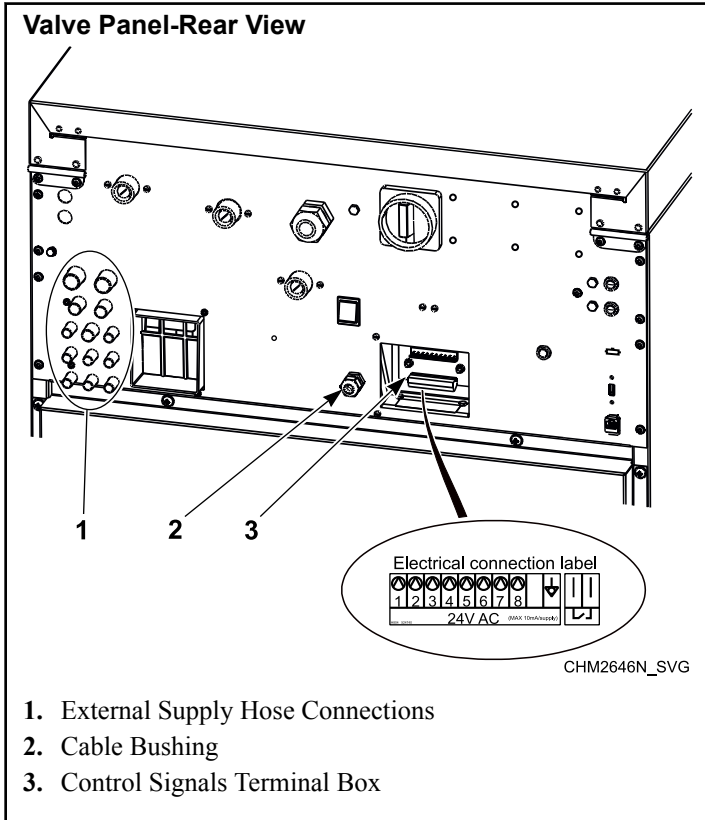

Figure 33

warranty. *Figure 34* shows a typical chemical injection supply system.

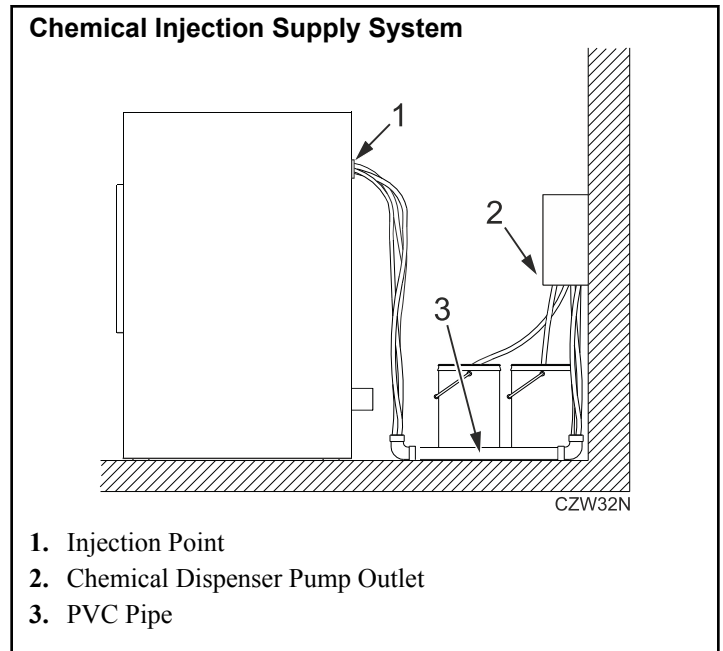

Figure 34

Chemical Injection Supply System

	WARNING
<p>Wear eye and hand protection when handling chemicals; always avoid direct contact with raw chemicals. Read the manufacturer's directions for accidental contact before handling chemicals. Ensure an eye-rinse facility and an emergency shower are within easy reach. Check at regular intervals for chemical leaks.</p>	
C365	

Undiluted chemical dripping can damage the washerextractor. Therefore, all chemical supply dispenser pumps should be mounted below the washerextractor's injection point. All dispenser tubing should also run below the injection point. Loops do not prevent drips if these instructions are not followed. Failure to follow these instructions could damage the machine and void the

Operation

Operating Instructions

1. Turn on main power source (circuit breaker).
2. Pull on the door handle to open the door.
3. Load to capacity whenever possible. DO NOT OVERLOAD. Refer to *Figure 35*.

NOTE: Underloading can cause out-of-balance conditions that can shorten machine life.

NOTE: Different fabrics have different densities. Loads must be adjusted accordingly to meet machine loading specifications. The optimal washing load is determined by the loading ratio (kg/lb linen : l/gal drum volume). The proper loading ratio is determined by the type of linen and other factors. Cotton textiles normally require a loading ratio of 1:10-1:13, which is a full drum load. Synthetics and blended fabrics usually require a loading ratio of 1:18-1:20, which is half drum load.

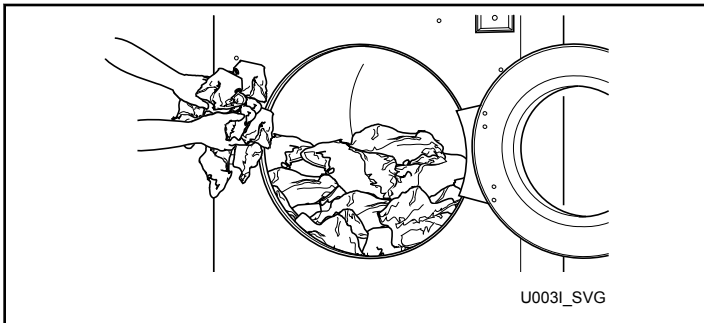

Figure 35

4. Close the door by applying moderate pressure on the door handle and simultaneously turning door handle partially to the left.
5. **NOTE: Make sure the door is closed properly before operating washing machine. Do not turn the handle completely around or the safety system will not engage. The safety system serves as protection against violent handling and damage to the door lock while the machine is operating.**
6. Choose the desired wash program best corresponding to the quality of the garments and allowed wash temperature in the wash load.

	WARNING
To prevent personal injury, avoid contact with inlet water temperatures higher than 125° Fahrenheit [51° Celsius] and hot surfaces.	
W748	

	WARNING
Water cannot be extracted from rubber backed items. To avoid damage to machine from out of balance conditions, do not use a spin (extract) step when washing rubber backed items. Warranty will be voided.	
W880	

7. Add liquid supplies to supply dispenser and close lid.

NOTE: It is advisable to use only detergents with "softener to break the suds", which can easily be found in retail shops. Do not use gel detergents. The dosage of soap is generally mentioned on the packing. An overdose of detergent can lead to poor wash results and suds or overflow which can damage the machine.

<ol style="list-style-type: none"> 1. Detergent for the pre-wash 2. Detergent for the main wash 3. Liquid detergent for the main wash or liquid bleach, etc. 4. Liquid fabric softener or liquid starch for the last rinse

Figure 36

8. For vended models only, insert coin(s) or card as necessary.
 - If the machine is a coin operated unit, add coins. As each coin is added, the vend counts down to the amount remaining.
9. Press the START keypad.
10. During first 150 seconds, the desired wash cycle can be changed. After first 150 seconds have ended, the wash cycle active at that moment remains the chosen wash cycle.
11. The wash cycle time is counted down to zero on the display. After completion, the door lock unlocks and the display shows "UNLOAD".

	WARNING
<p>If, after a power disconnect, the machine door cannot be opened and the machine is fitted with an automatic unlocking circuit, wait until the locking circuit unlocks the door lock. Before you open the door, make sure that the drum is completely still and all water has drained.</p>	
W903	

	WARNING
<p>The automatic door-lock unlocking module must not be utilized on machines that are fitted with a drain pump or reverse function drain valve.</p>	
W910	

Power Cut

If a power cut occurs in an idle condition of the machine and no wash program is running, the machine remains in the idle condition.

Models without numeric keypad

If a power cut occurs during the wash process and the door remains closed and locked, the wash program will, after the power supply has been restored, automatically continue in the program beginning from the step in which the program was interrupted.

For machines fitted with an automatic door-lock unlocking module, refer to *Automatic Door-lock Unlocking Module (Optional)* section. If during the power cut, the door lock gets unlocked and the door remains closed, the message "PRESS START / OPEN DOOR" appears as soon as the power supply is restored. If you open the door, the wash program will be cancelled. If you press the START button, the wash program will continue beginning from the step in which the program was interrupted.

Models with numeric keypad

If a power cut occurs during the wash process, the message "CONTINUE / STOP" appears as soon as the power supply is restored. If you press the STOP button, the wash program will be cancelled. If you press the START button, the wash program will continue beginning from the step in which the program was interrupted.

Automatic Door-lock Unlocking Module (Optional)

Some machines are fitted with an automatic module for unlocking the door lock in case of a power cut.

If a short term power cut occurs, this module does not affect the operation of the machine.

If a long term power cut occurs, the module unlocks the door lock. It is then possible to open the door and remove laundry.

Maintenance

Maintenance

	WARNING
<p>Use the proper chemical agents which avoid calcium sediments on heating elements and other machine parts. Discuss the issue with your supplier of washing products. The manufacturer of the machine is not responsible for the damage of heating elements and other machine parts due to calcium sediments.</p>	
W904	

	WARNING
<p>Sharp edges can cause personal injury. Wear safety glasses and gloves, use proper tools and provide lighting when handling sheet metal parts.</p>	
W366R1	

IMPORTANT: Replace all panels that are removed to perform service and maintenance procedures. Do not operate the machine with missing guards or with broken or missing parts. Do not bypass any safety devices.

Daily

IMPORTANT: Replace all panels that are removed to perform maintenance procedures. Do not operate the machine with missing guards or with broken or missing parts. Do not bypass any safety devices.

	WARNING
<p>Do not spray the machine with water. Short circuiting and serious damage may result.</p>	
W782	

IMPORTANT: Door lock should be checked daily to ensure proper operation. Also check that all safety and instruction stickers are on the machine. Any missing or illegible safety instructions stickers should be replaced immediately.

Beginning of Day

1. Check door interlock before starting operation:
 - a. Attempt to start the machine with the door open. The machine should not start.

- b. Close the door without locking it and start the machine. The machine should not start.
- c. Attempt to open the door while the cycle is in progress. The door should not open.

If the door lock and interlock are not functioning properly, disconnect power and call a service technician.

2. Check the machine for leaks.
 - a. Start an unloaded cycle to fill the machine.
 - b. Verify that door and door gasket do not leak.
 - c. Verify that the drain valve is operating and that the drain system is free from obstruction. If water does not leak out during the first wash segment, the drain valve is closed and functioning properly.
3. Inspect water inlet valve hose connections on the back of the machine for leaks.
4. Inspect steam hose connections for leaks (if applicable).
5. On machines equipped with an automatic Chemical Supply System, check all the hoses and hose connections for leaks or visible signs of deterioration. Replace immediately if either are present. Chemical leaks can cause damage to the machine's components.

	WARNING
<p>To reduce the risk of electrical shock, serious injury or death, disconnect the electrical power to washer-extractor before examining the wiring.</p>	

6. Verify that insulation is intact on all external wires and that all connections are secure. If bare wire is evident, call a service technician.
7. Ensure all panels and guards are properly installed.

End of Day

1. Inspect and clean the basket and door gasket of residual detergent and all foreign matter.
2. Clean the door glass and between the door gasket and the door with a damp cloth.
3. Clean supply dispenser lid and general area with mild detergent. Flush the dispenser with clean water.
4. Clean the machine's top, front and side panels with all-purpose cleaner. Rinse with clean water and dry.

IMPORTANT: Use only isopropyl alcohol to clean graphic overlays. Never use ammonia-based, vinegar-based or acetone-based cleaners on graphic overlays.

IMPORTANT: Do not use abrasive cleaners.

NOTE: Unload the machine promptly after each completed cycle to prevent moisture buildup. Leave loading door open at the end of each completed cycle to allow moisture to evaporate.

5. Leave the loading door open at the end of each day to allow moisture to evaporate.
6. Shut off water supply.

Quarterly

NOTE: Disconnect power to the machine at its source before performing the quarterly maintenance procedures.

1. Check the bearing house for leakage.
2. Verify that the drain valve is operating and that the drain system is free from obstruction. If water does not leak out during the first wash segment, the drain valve is closed and functioning properly.
3. Visually check all hoses and connections inside machine for leaks.
4. Make sure that control components are protected against moisture and dust during the clean up. Wipe and clean the machine inside.
5. For models with electric heat, check the tightening of the contacts of heating elements terminals and other power terminals (main switch, fuse disconnectors, contactors).
6. In order to increase the service life of the door gasket, apply a glycerine-based impregnating agent.

Every 6 Months

NOTE: Disconnect power to the machine at its source before performing maintenance procedures.

1. Clean the water valve filters.

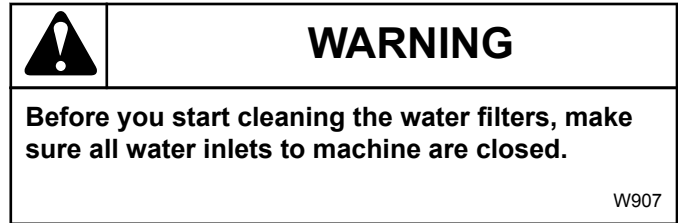

- a. Turn off the water supply.
 - b. Unscrew the hoses at the back of machine.
 - c. Take out filter at center with pointed pliers.
 - d. Clean the filter and re-insert.
 - e. When reattaching the hoses, make sure the seals are seated correctly.
 - f. Check water inlets for leaks.
 - g. Tighten the connections or replace the seals of inlet hose if necessary.
2. If machine is fitted with a drain pump, make sure the pump provides normal flow rate during draining. The drain pump can be cleaned when it becomes clogged with foreign objects.
 - a. Drain all water from machine.
 - b. Disconnect machine from power supply.
 - c. Remove the front panel of cabinet by unlocking bolts. Refer to *Figure 37*.

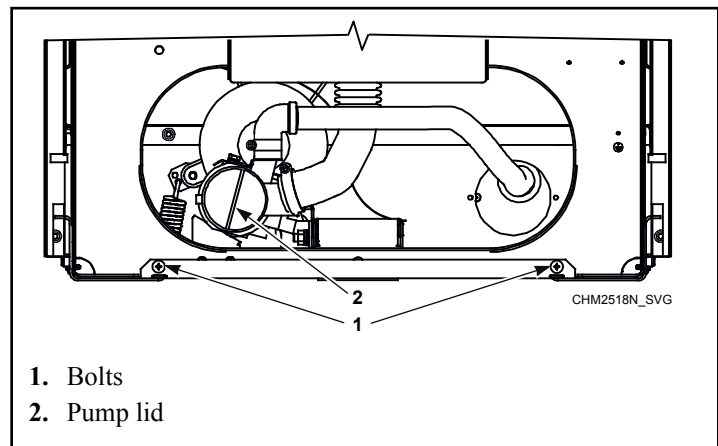



Figure 37

- d. Slightly turn the pump lid until water starts flowing out, making sure to catch the water.
 - e. Unscrew the lid and remove any foreign objects.
 - f. Reattach pump lid and front panel of cabinet.
3. Remove dust or dirt and verify functionality of the following:
 - a. Inverter cooling fin

	WARNING
<p>Before removing top or back panel of machine, switch power off and wait for at least 10 minutes. Before starting inspection of frequency inverter, check for residual voltage across main circuit terminals. This voltage must be below 30 VDC before you can access the inverter for inspection.</p>	
W905	

- b. Motor cooling fins
- c. Interior inverter ventilator (if present)
- d. Exterior inverter ventilator (if present)

IMPORTANT: All torque joints must remain dry (non-lubricated).

- 4. Check for belts for wear and inspect tightness. For recommended values, refer to *Table 31* .

Model	Torque, Hz
7.5 kg / 20 lb. / 80 L	88 - 98
10.5 kg/ 25 lb. / 105 L	62 - 67
13.5 kg / 30 lb. / 135 L	73 - 78
18 kg/ 40 lb. / 180 L	56 - 61
24 kg / 55 lb. / 240 L	63 - 73
28 kg / 70 lb. / 280 L	80 - 86
35 kg / 80 lb. / 332 L	59 - 66
52 kg / 120 lb. / 520 L	68 - 75

Table 31

- 5. Check the tightness of bolts. Refer to *Table 32* .

Item	Bolt Type	Torque, lb. ft. [Nm]
Door lock bolts	M5	1.84 [2.5]
Door handle central bolt	M6	6.49 [8.8]
Door hinge and front panel bolts	M6	6.49 [8.8]
Anchoring bolts	M16	73.76 [100]
External tub bolts	M8	19.18 [26]
Motor bolts	M12	N/A

Table 32

Care of Stainless Steel

- Remove dirt and grease with detergent and water. Thoroughly rinse and dry after washing.
- Avoid contact with dissimilar metals to prevent galvanic corrosion when salty or acidic solutions are present.
- Do not allow salty or acidic solutions to evaporate and dry on stainless steel. Wipe clean of any residues.
- Rub in the direction of the polish lines or “grain” of the stainless steel to avoid scratch marks when using abrasive cleaners. Use stainless steel wool or soft, non-metal bristle brushes. Do not use ordinary steel wool or steel brushes.
- If the stainless steel appears to be rusting, the source of the rust may be an iron or steel part not made of stainless steel, such as a nail or screw.
- Remove discoloration or heat tint from overheating by scouring with a powder or by employing special chemical solutions.
- Do not leave sterilizing solutions on stainless steel equipment for prolonged periods of time.
- When an external chemical supply is used, ensure no siphoning of chemicals occurs when the machine is not in use. Highly concentrated chemicals can cause severe damage to stainless steel and other components within the machine. Damage of this kind is not covered by the manufacturer’s warranty. Locate the pump and tubing below the machine’s injection point to prevent siphoning of chemicals into the machine.

Disposal of Unit

Disconnecting the Machine

1. Switch off the external electric power inlet to machine.
2. Turn off the main switch on machine.
3. Shut the external water or steam inlets to machine.
4. Make sure the external electric power and steam inlets are shut off. Disconnect all electric, water or steam inlets.
5. Insulate the external electric power inlet conductors.
6. Equip the machine with an "Out of Service" sign.
7. Unscrew nuts and bolts that fix machine to floor.
8. If the machine will never be used again, secure it so injury to persons and damage to health, property and nature is avoided. Remove the door, secure the drum so it does not turn and remove any sharp parts of machine so enclosure or injury of a person or animal will not occur.

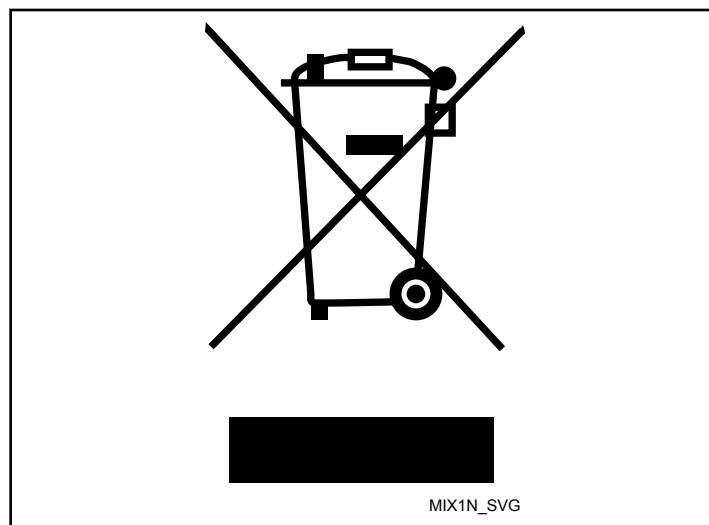

Figure 38

	CAUTION
<p>Be careful when disconnecting machine from service. Falling door and glass can cause injuries.</p>	
W922	

	WARNING
<p>Take all necessary action and precautions when disassembling the washer to avoid injury from glass or sharp metal edges.</p>	
W908	

Disposal of Unit

This appliance is marked according to the European directive 2002/96/EC on Waste Electrical and Electronic Equipment (WEEE).

This symbol on the product or on its packaging indicates that this product shall not be treated as household waste. Refer to *Figure 38*. Instead it shall be handed over to the applicable collection point for the recycling of electrical and electronic equipment. Ensuring this product is disposed of correctly will help prevent potential negative consequences for the environment and human health which could otherwise be caused by inappropriate waste handling of this product. The recycling of materials will help to conserve natural resources. For more detailed information about recycling of this product, please contact the local city office, household waste disposal service, or the source from which the product was purchased.

China Restriction of hazardous substances (RoHS)

The Table of Hazardous Substances/Elements and their Content

As required by China's Management Methods for Restricted Use of Hazardous Substances in Electrical and Electronic Products

Hazardous substances						
Part Name	Lead (Pb)	Mercury (Hg)	Cadmium (Cd)	Hexavalent Chromium (CR[VI])	Polybrominated biphenyls (PBB)	Polybrominated diphenyl ethers (PBDE)
PCBs	X	O	O	O	O	O
Electromechanical Parts	O	O	O	O	O	O
Cables and Wires	O	O	O	O	O	O
Metal Parts	O	O	O	O	O	O
Plastic Parts	O	O	O	O	O	O
Batteries	O	O	O	O	O	O
Hoses and Tubing	O	O	O	O	O	O
Textile	O	O	O	O	O	O
Timing Belts	O	O	O	O	O	O
Insulation	O	O	O	O	O	O
Glass	O	O	O	O	O	O
Display	O	O	O	O	O	O

This table is prepared in accordance with the provisions of SJ/T-11364.

O: Indicates that the content of said hazardous substance in all of the homogenous materials in the component is within the limits required by GB/T 26572.

X: Indicates that the content of said hazardous substance exceeds the limits required by GB/T 26572 in at least one homogenous material in the component.

All parts named in this table with an "X" are in compliance with the European Union's RoHS Legislation.

NOTE: The referenced Environmental Protection Use Period Marking was determined according to normal operating use conditions of the product such as temperature and humidity.



This product under normal use, durable years of environmental protection is 15 years.